



UT

UT1B/G4-0ESY

Ultra.M30,NPN+4-20mA,M12 plug,Diffuse
M30 CYLINDRICAL DIRECT DIFFUSE &
RETRO-REFLECTIVE ULTRASONIC SENSOR WITH
TEACH-IN BUTTON

OVERVIEW

- M30 ultrasonic sensor with standard housing and with large front with high performances and high sensing distances
- Adjustable hysteresis function: models with double digital programmable output specific for level detection
- Models with voltage or current output: programmable slope to optimize resolution
- Adjustable working area (window mode or object mode) by Teach-in button on all models for a quick and easy installation
- Two multifunction LEDs: orange LED for adjustment procedure and output type and green LED for target alignment
- Plastic and AISI 316L stainless steel housing, plug M12 or cable exit 4 pin

TECHNICAL FEATURES

Detection properties

Nominal sensing distance

Thermal drift of Sr

Repeat Accuracy

Beam angle

Resolution

Sensitivity adjustment

Teach-in button

Hysteresis

thermal compensation

Minimum sensing distance (blind zone)

Linearity error

Application

Function Principle

Diffuse reflection

Outputs

Output type

NPN + 4...20mA

Output Function

NO/NC + positive/negative slope

Switching frequency

Response time

Electrical data

Operating Voltage

No-Load supply current

Load current

Leakage current

Output voltage drop

Max ripple content

LED indicators

Time delay before availability

Short-circuit protection

Reverse Polarity Protection

Impulsive Overvoltage Protection

Mechanical data

Dimensions

Housing material

Weight

Connections

M12 Plug

Tightening torque

Operating temperature

Storage temperature

Transducer Frequency

Diameter/Dimension

M30

Test/Approvals

Approvals

EMC compatibility

Shocks and vibrations

Degree of protection

Accessories

Supplied Accessories

Generical Data

Dimensions

Operating Temperature

Mechanical Protection

OTHERS

Dimensions

M12 x 1

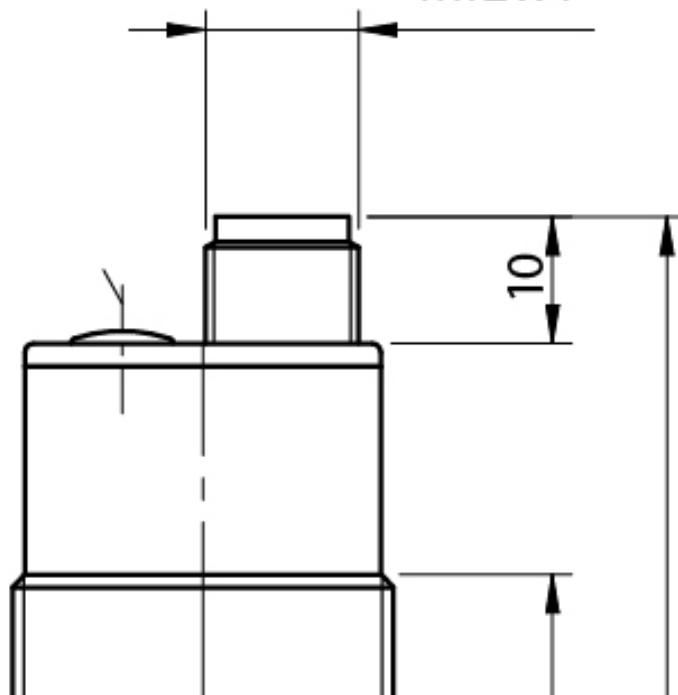

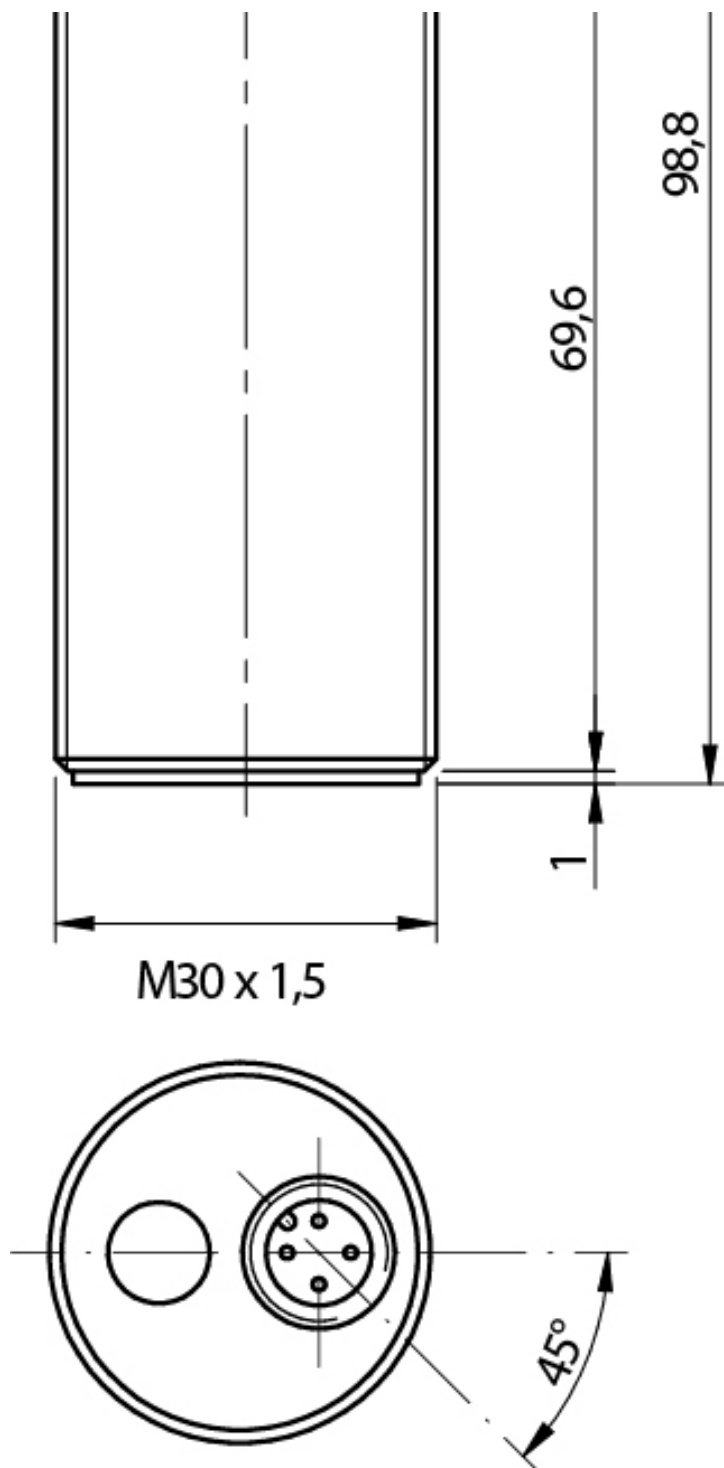

**Datasensing
S.r.l.**

Strada S.Caterina, 235
41122 Modena (MO)
Tel. 059 420411
Fax 059 253973
E-mail
info@datasensing.com

**date of
printing**
19/06/2026
11:01:23