



PFM

PFM1/AN-1H

Ind.M12,NPN-NO,M12 plug,Sch-STD

M12 CYLINDRICAL INDUCTIVE SENSORS FOR FOOD AND BEVERAGE APPLICATIONS

OVERVIEW

- AISI 316L (DIN 1.4404) stainless steel housing
- LED status indicator
- IP67 – IP68 – IP69K protection degree
- ATEX models, cat. 3, available on request
- Complete protection against electrical damages
- Standard and long distance models



TECHNICAL FEATURES

Detection properties

Nominal sensing distance	2mm
Operanting distance	0...1,62mm
Standard target	12x12mm FE360
Correction Factor	copper: 0,25 / aluminium: 0,30 / brass: 0,40 / stainless steel: 0,75
Thermal drift of Sr	< 10%

Repeat Accuracy	< 5% (UB 24V Ta=23°C ±5°C)
-----------------	----------------------------

Hysteresis	1 ... 20%
------------	-----------

Application

Description	M12 standard flush mount
-------------	--------------------------

Functions	Proximity
-----------	-----------

Outputs

Output type	NPN
-------------	-----

Output Function	NO
-----------------	----

Switching frequency	2kHz
---------------------	------

Electrical data

Operating Voltage	10...30Vdc
-------------------	------------

No-Load supply current	≤ 15mA
------------------------	--------

Load current	≤ 200mA
--------------	---------

Leakage current	≤ 15μA
-----------------	--------

Output voltage drop	≤ 2V @200mA
---------------------	-------------

Max ripple content	≤ 10%
--------------------	-------

LED indicators	Yellow LED output state
----------------	-------------------------

Time delay before availability	≤ 50ms
--------------------------------	--------

Short-circuit protection	Yes
Reverse Polarity Protection	Yes
Impulsive Overvoltage Protection	Yes
Protection against inductive loads	Yes

Mechanical data

Mounting	Shielded
Dimensions	M12 x 1 / L = 64,6mm
Weight	30g
Housing Material	AISI316L Stainless Steel
Connections	M12 Plug
Active Head Material	PPS
Tightening torque	25Nm
Operating temperature	-40°C...+80°C (up to 100°C for short exposure during cleaning process)
Material	AISI316L Stainless Steel
Diameter/Dimension	M12

Test/Approvals

Approvals	CE cULus ECOLAB DIVERSEY
EMC compatibility	IEC 60947-5-2
Shocks and vibrations	Vibration IEC 60068-2-6 / Shock IEC 60068-2-27

Degree of protection	IP68, IP69K
----------------------	-------------

Accessories

Supplied Accessories	2 nuts M12x1
----------------------	--------------

Generical Data

Dimensions	M12 x 1 / L = 64,6mm
------------	----------------------

Operating Temperature	-40°C...+80°C (up to 100°C for short exposure during cleaning process)
-----------------------	--

Mechanical Protection	IP67
-----------------------	------

CONNECTIONS

Electrical diagram

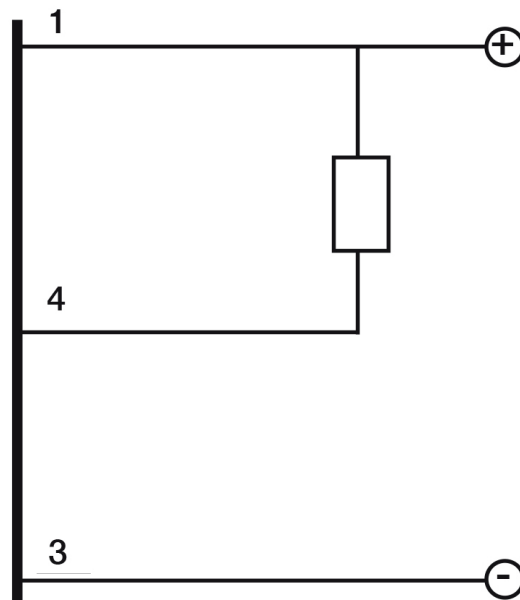

Connector

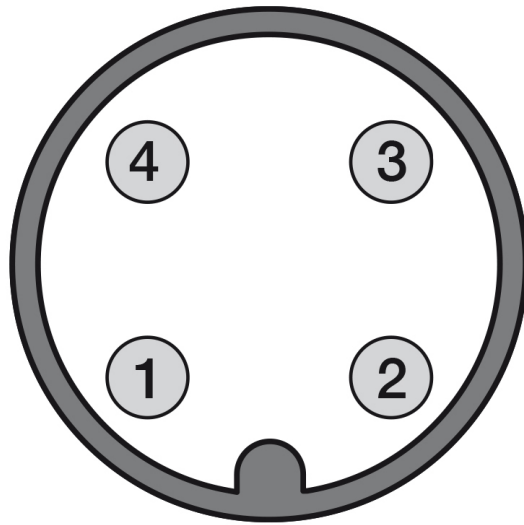

OTHERS

Dimensions

M12 x 1

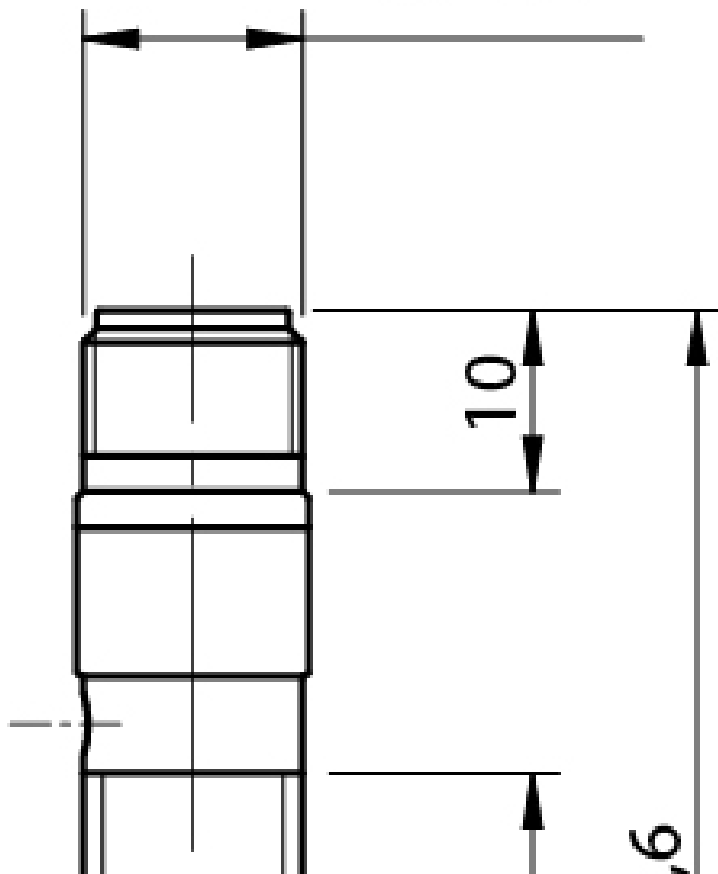

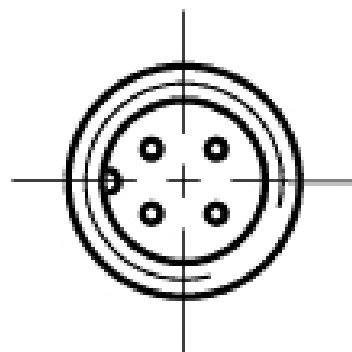
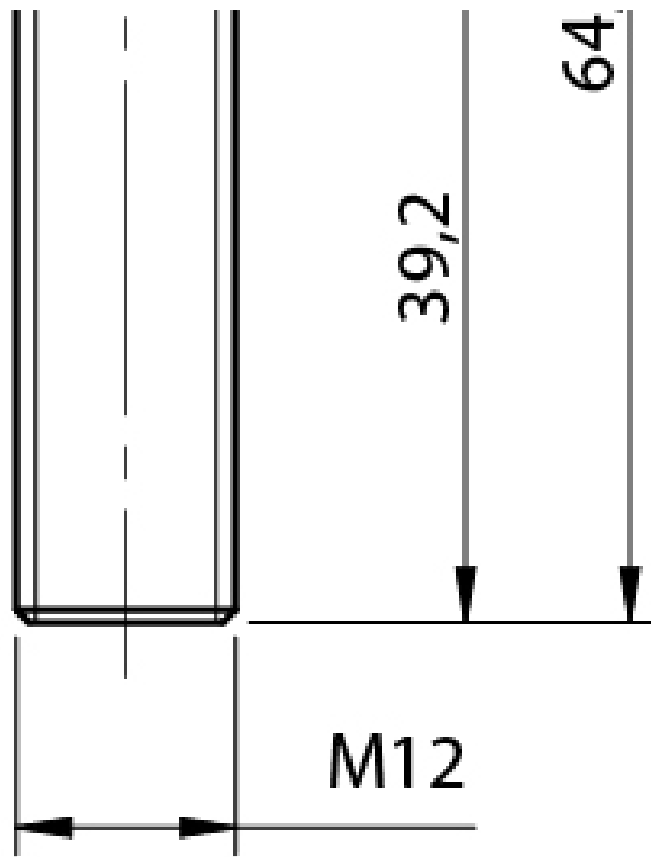

Response curves

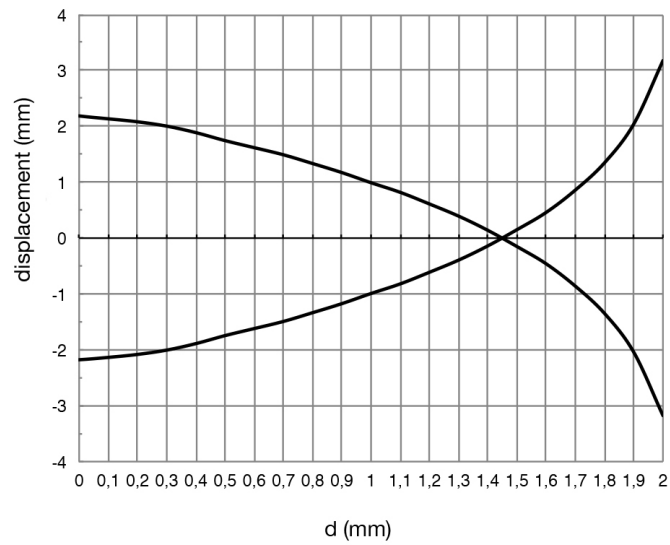

Installation

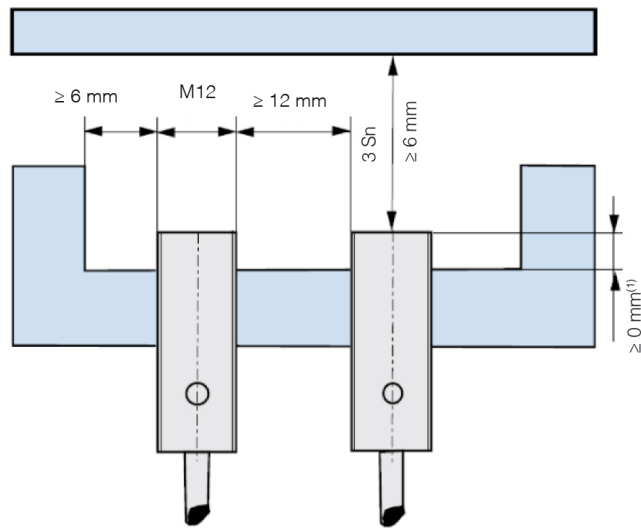

⁽¹⁾ ≥ 2 mm for non magnetic materials

Datasensing S.r.l.

Strada S.Caterina, 235
41122 Modena (MO)
Tel. 059 420411
Fax 059 253973
E-mail
info@datasensing.com

**date of
printing**
05/04/2026
16:40:50