



# VK

## VK2/A0-2B

Ind.M18,2 wires AC-NO,Cable,Nsch-STD  
CYLINDRICAL M18 IN AC INDUCTIVE SENSORS

## OVERVIEW

- Output: cable and M12 plug cable exit
- Models with 2 wires
- IP 67 protection degree
- Multivoltage 20 ...253 Vac



## TECHNICAL FEATURES

### Detection properties

Nominal sensing distance	8mm
Operating distance	0...6,48mm
Standard target	24x24mm FE360
Correction Factor	copper: 0,40 / aluminium: 0,45 / brass: 0,55 / stainless steel: 0,95
Thermal drift of Sr	< 10%
Repeat Accuracy	< 5% (UB 24V Ta=23°C ±5°C)

Hysteresis	1 ... 20%
------------	-----------

#### Application

Description	M18 standard no-flush mount
-------------	-----------------------------

Functions	Proximity
-----------	-----------

#### Outputs

Output type	TRIAC
-------------	-------

Output Function	NO
-----------------	----

Switching frequency	25Hz
---------------------	------

#### Electrical data

Operating Voltage	20...250Vac/50...60Hz
-------------------	-----------------------

Load current	5...300mA
--------------	-----------

Leakage current	$\leq 1\text{mA RMS max}$
-----------------	---------------------------

Output voltage drop	See curves
---------------------	------------

Max ripple content	$\leq 10\%$
--------------------	-------------

LED indicators	Yellow LED output state
----------------	-------------------------

Time delay before availability	$\leq 200\text{ms}$
--------------------------------	---------------------

Inrush current	7A (Ton = 10ms)
----------------	-----------------

#### Mechanical data

Mounting	Unshielded
Dimensions	M18 x 1 / L = 77mm
Weight	107g
Housing Material	Nickel-plated brass
Connections	2m PVC cable with tang
Active Head Material	PBT
Tightening torque	25Nm
Operating temperature	-25°C...+70°C
Material	Nickel-plated brass
Diameter/Dimension	M18

#### Test/Approvals

Approvals	CE UR
EMC compatibility	IEC 60947-5-2
Shocks and vibrations	Vibration IEC 60068-2-6 / Shock IEC 60068-2-27
Degree of protection	IP67

#### Accessories

Supplied Accessories	2 nuts M18x1
----------------------	--------------

#### Generical Data

Dimensions	M18 x 1 / L = 77mm
------------	--------------------

Operating Temperature	-25°C...+70°C
Mechanical Protection	IP67

## CONNECTIONS

Electrical diagram

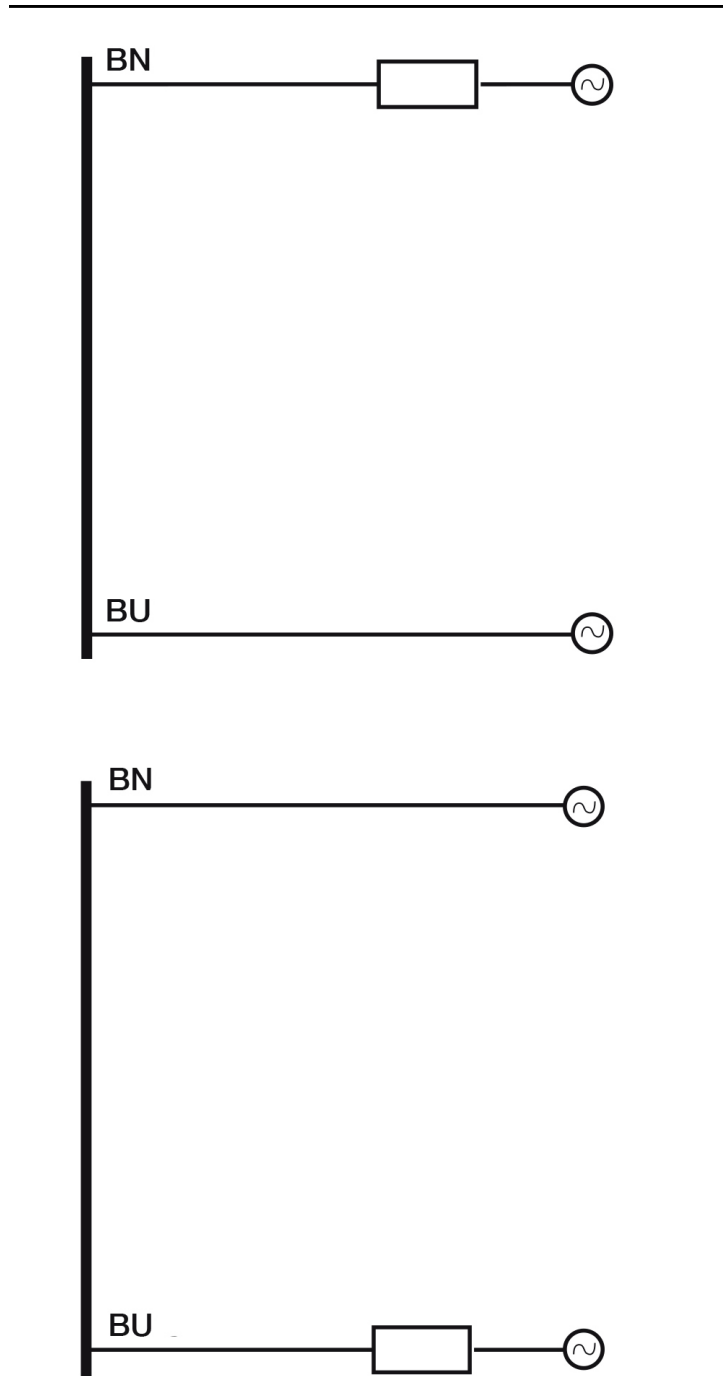

# OTHERS

Dimensions

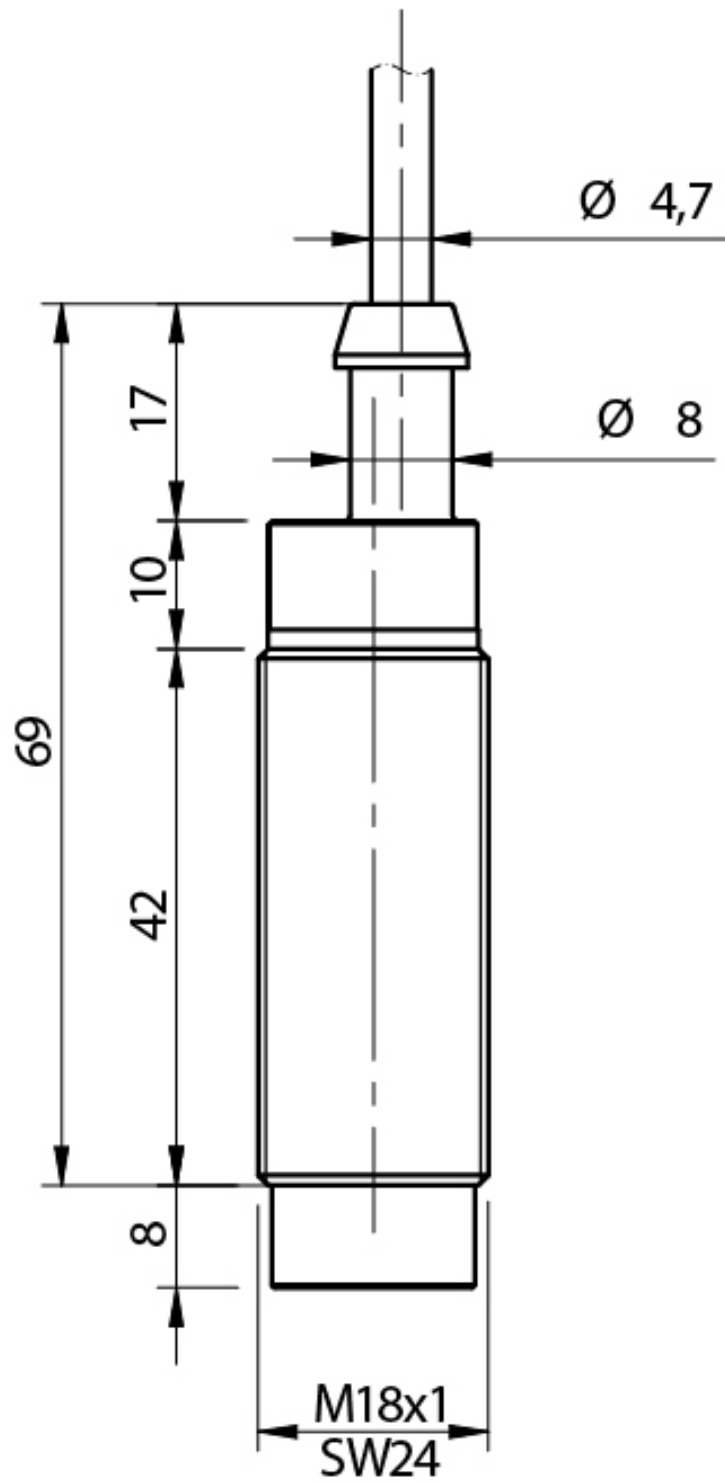

Response curves

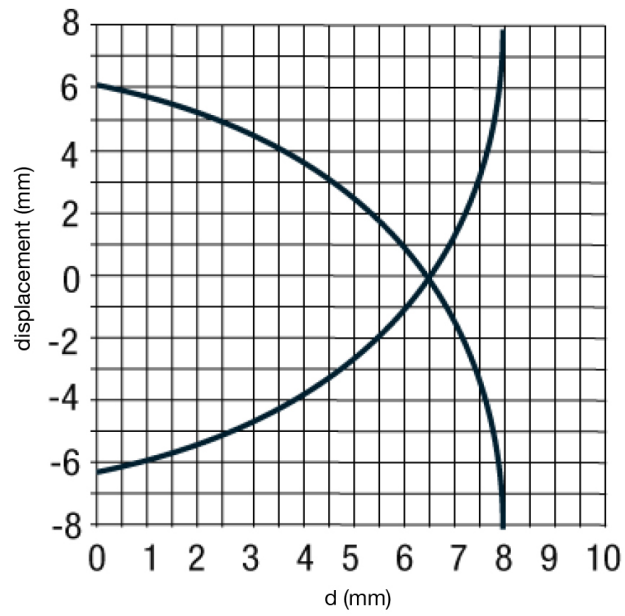

Installation

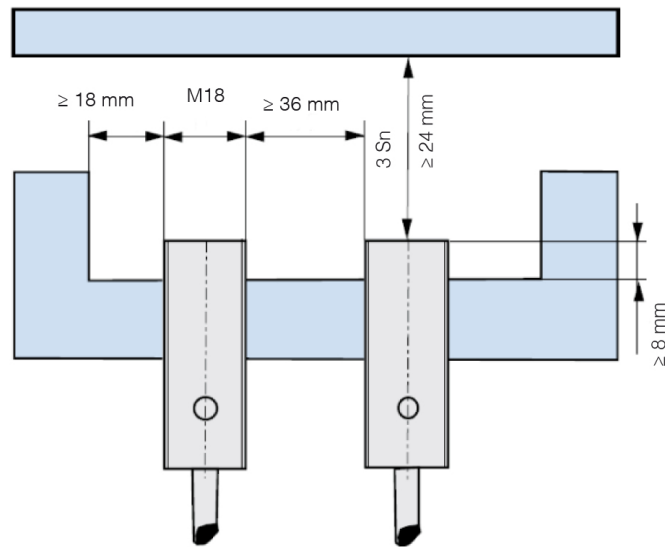

**Datasensing  
S.r.l.**  
 Strada S.Caterina, 235  
 41122 Modena (MO)  
 Tel. 059 420411  
 Fax 059 253973  
 E-mail  
 info@datasensing.com

**date of  
printing**  
 11/04/2026  
 15:32:10