

# INSTRUCTION MANUAL



## > SG4-H Safety Light Curtains



**ORIGINAL INSTRUCTIONS (ref. 2006/42/EC)**

Patent. See [www.patents.datalogic.com](http://www.patents.datalogic.com) for patent list.  
This product is covered by one or more of the following patents: IT1427752

Datalogic S.r.l.  
Via S. Vitalino 13  
40012 Calderara di Reno  
Italy

“SG4-H” Instruction Manual

Ed.: 07/2017 Rev.A

© 2016 – 2017 Datalogic S.p.A. and/or its affiliates ♦ ALL RIGHTS RESERVED. ♦ Without limiting the rights under copyright, no part of this documentation may be reproduced, stored in or introduced into a retrieval system, or transmitted in any form or by any means, or for any purpose, without the express written permission of Datalogic S.p.A. and/or its affiliates.

Datalogic and the Datalogic logo are registered trademarks of Datalogic S.p.A. in many countries, including the U.S.A. and the E.U. All other trademarks and brands are property of their respective owners.

Datalogic shall not be liable for technical or editorial errors or omissions contained herein, nor for incidental or consequential damages resulting from the use of this material.



Product Service

# CERTIFICATE

No. Z10 17 02 70800 046

**Holder of Certificate:** **Datalogic S.r.l.**  
Via San Vitalino 13  
40012 Lippo di Calderara di Reno  
ITALY

**Factory(ies):** 70800, 96012

**Certification Mark:**



**Product:** **Electro-Sensitive Protective Equipment  
Safety Light Curtain (Type 4)**

**Model(s):** **SG4-Series  
For nomenclature see attachment**

**Parameters:**

Supply Voltage:	24 ±20% Vdc
Resolution:	14mm, 30mm or 2, 3, 4 beams
Protection class:	IP65

**Tested according to:**

- 2006/42/EC
- EN 61496-1:2013
- EN 61496-2:2013
- EN ISO 13849-1:2015 (Cat.4, PL e)
- EN 61508-1:2010 (SIL3)
- EN 61508-2:2010 (SIL3)
- EN 61508-3:2010 (SIL3)
- EN 61508-4:2010 (SIL3)
- EN 62061:2005/A2:2015 (SIL CL3)

The product was tested on a voluntary basis and complies with the essential requirements. The certification mark shown above can be affixed on the product. It is not permitted to alter the certification mark in any way. In addition the certification holder must not transfer the certificate to third parties. See also notes overleaf.

**Test report no.:** DM82444T

**Valid until:** 2021-07-04

**Date,** 2017-02-13

Page 1 of 4

( Christian Dirmeier )



## **CE COMPLIANCE**

CE marking states the compliance of the product with essential requirements listed in the applicable European directive. Since the directives and applicable standards are subject to continuous updates, and since Datalogic promptly adopts these updates, therefore the EU declaration of conformity is a living document. The EU declaration of conformity is available for competent authorities and customers through Datalogic commercial reference contacts. Since April 20<sup>th</sup>, 2016 the main European directives applicable to Datalogic products require inclusion of an adequate analysis and assessment of the risk(s). This evaluation was carried out in relation to the applicable points of the standards listed in the Declaration of Conformity. Datalogic products are mainly designed for integration purposes into more complex systems. For this reason it is under the responsibility of the system integrator to do a new risk assessment regarding the final installation.

### **Warning**

This is a Class A product. In a domestic environment this product may cause radio interference in which case the user may be required to take adequate measures.

- 1 GENERAL INFORMATION ..... 6**
- 1.1 General description ..... 6
- 1.2 Package contents ..... 7
- 1.3 How to choose the device ..... 8
- 1.3.1 Detection capability ..... 8
- 1.3.2 Height of the detection zone ..... 9
- 1.3.3 Minimum installation distance ..... 10
- 1.4 Typical applications ..... 12
- 1.5 Safety information ..... 13
  
- 2 INSTALLATION ..... 14**
- 2.1 Precautions to be observed for the choice and installation ..... 14
- 2.2 General information on device positioning ..... 15
- 2.2.1 Minimum distance from reflecting surfaces ..... 16
- 2.2.2 Distance between homologous devices ..... 18
- 2.2.3 Emitter and Receiver Orientation ..... 20
- 2.2.4 Use of deviating mirrors ..... 21
- 2.2.5 Controls after first installation ..... 22
  
- 3 MECHANICAL MOUNTING ..... 23**
  
- 4 ELECTRICAL CONNECTIONS ..... 24**
- 4.1 Pin-out and configuration pin connection ..... 24
- 4.2 Notes on connections ..... 25
  
- 5 ALIGNMENT PROCEDURE ..... 27**
  
- 6 FUNCTIONS SETTING ..... 29**
  
- 7 USER INTERFACE AND DIAGNOSTICS ..... 30**
- 7.1 User interface ..... 30
- 7.2 Diagnostic messages ..... 31
  
- 8 PERIODICAL CHECKS ..... 33**
- 8.1 General information and useful data ..... 34
- 8.2 Warranty ..... 34
  
- 9 DEVICE MAINTENANCE ..... 35**
- 9.1 Product disposal ..... 35
  
- 10 TECHNICAL DATA ..... 36**
  
- 11 AVAILABLE MODELS ..... 37**
  
- 12 OVERALL DIMENSIONS ..... 38**
  
- 13 ACCESSORIES ..... 39**
- 13.1 (TP) Test piece ..... 39
- 13.2 Connection cables ..... 40
- 13.3 (SE-SR2) Safety relay ..... 41
  
- 14 GLOSSARY ..... 42**

# 1 GENERAL INFORMATION

## 1.1 GENERAL DESCRIPTION

The safety light curtains are optoelectronic multibeam devices that are used to protect working areas that, in presence of machines, robots, and automatic systems in general, can become dangerous for operators that can get in touch, even accidentally, with moving parts.

The light curtains are intrinsic safety systems used as accident-prevention protection devices and are manufactured in accordance with the international Standards in force for safety, in particular:

NORM	DESCRIPTION
EN 61496-1: 2013	Safety of machinery: electrosensitive protective equipment. Part 1: General prescriptions and tests.
EN 61496-2: 2013	Safety of machinery: electrosensitive protective equipment - Particular requirements for equipment using active optoelectronic protective devices.
EN ISO 13849-1: 2015	Safety of machinery. Safety-related parts of control systems. Part 1: General principles for design
EN 61508-1: 2010	Functional safety of electrical/electronic/programmable electronic safety-related systems. Part 1: General requirements
EN 61508-2: 2010	Functional safety of electrical/electronic/programmable electronic safety-related systems. Part 2: Requirements for electrical/electronic/programmable electronic safety-related systems
EN 61508-3: 2010	Functional safety of electrical/electronic/programmable electronic safety-related systems. Part 3: Software requirements
EN 61508-4: 2010	Functional safety of electrical/electronic/programmable electronic safety-related systems. Part 4: Definitions and abbreviations
EN 62061:2005/A2: 2015	Safety of machinery. Functional safety of electrical/ electronic/programmable electronic safety-related control systems.

The device, consisting of one emitter and one receiver contained inside aluminium profiles, generates infrared beams that detect any opaque object positioned within the light curtain detection field.

The emitter and the receiver are equipped with the command and control functions.

The connections are made through one or more connectors as specified in cfr.**ELECTRICAL CONNECTIONS page 24**.

The synchronisation between the emitter and the receiver takes place optically, i.e. no electrical connection between the two units is required.

The microprocessor guarantees the check and the management of the beams that are sent and received through the units: the microprocessor – through some LEDs – informs the operator about the general conditions of the safety light curtain (cfr.**USER INTERFACE AND DIAGNOSTICS page 30**).

The receiver is the main controller for all functions. It monitors all safety actions in case of failure and performs general functions as well.

During installation, an user interface facilitates the alignment of both units (cfr.**ALIGNMENT PROCEDURE page 27**).

As soon as an object, or a limb or the operator’s body accidentally interrupts one or some of the infrared beams sent by the emitter, the receiver immediately opens the OSSD outputs or trigger Safety State over connected safety Fieldbus.

Some parts or sections of this manual containing important information for the user or installing operator are preceded by a note:



**Notes and detailed descriptions about particular characteristics of the safety devices in order to better explain their functioning. Special instructions regarding the installation process.**

This manual contains all the information necessary for the selection and operation of the safety devices.

However, specialised knowledge not included in this technical description is required for the planning and implementation of a safety light curtain on a power-driven machine.

As the required knowledge may not be completely included in this manual, we suggest the customer to contact Datalogic Technical Service for any necessary information relative to the functioning of the light curtains and the safety rules that regulate the correct installation (cfr. **USER INTERFACE AND DIAGNOSTICS page 30**).

## 1.2 PACKAGE CONTENTS

Package contains the following objects:

- Receiver (RX)
- Emitter (TX)
- Quick Guide of safety light curtain
- Periodical checklist and maintenance schedule
- Mini-DVD with instruction manual and other documents

### 1.3 HOW TO CHOOSE THE DEVICE

There are at least three different main characteristics that should be considered when choosing a safety light curtain, after having evaluated the risk assessment.

#### 1.3.1 Detection capability

The detection capability (or resolution) of the device is the minimum diameter that an opaque object must have in order to obscure at least one of the beams that constitute the detection zone and to actuate the sensing device. The resolution is related to the part of the body to be protected.

**R=14mm**

finger protection

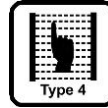

As shown in **Fig 1 - page 8**, the resolution only depends on the geometrical characteristics of the lenses, diameter and distance between centres, and is independent of any environmental and operating conditions of the safety light curtain.

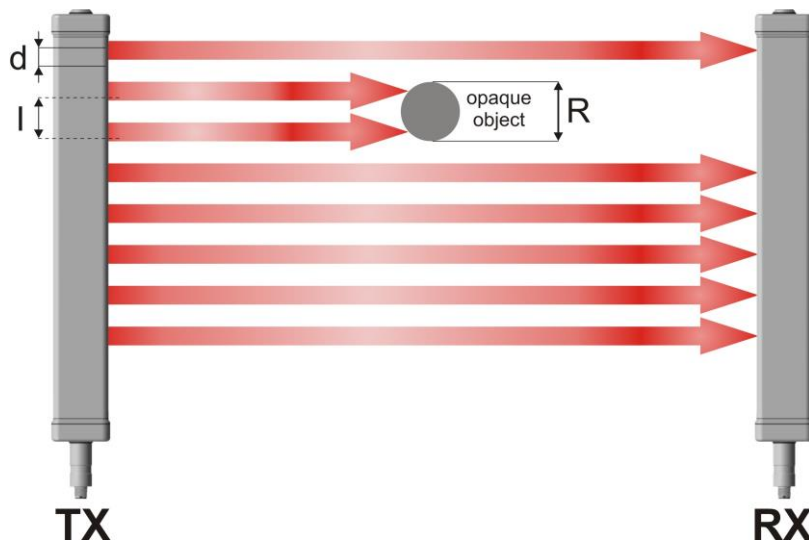

**Fig 1 - Detection capability**

The resolution value is obtained applying the following formula:

$$R = l + d$$

where:

l=Interaxes between two adjacent optics

d=Lens diameter



### 1.3.2 Height of the detection zone

The controlled height is the height protected by the safety light curtain.

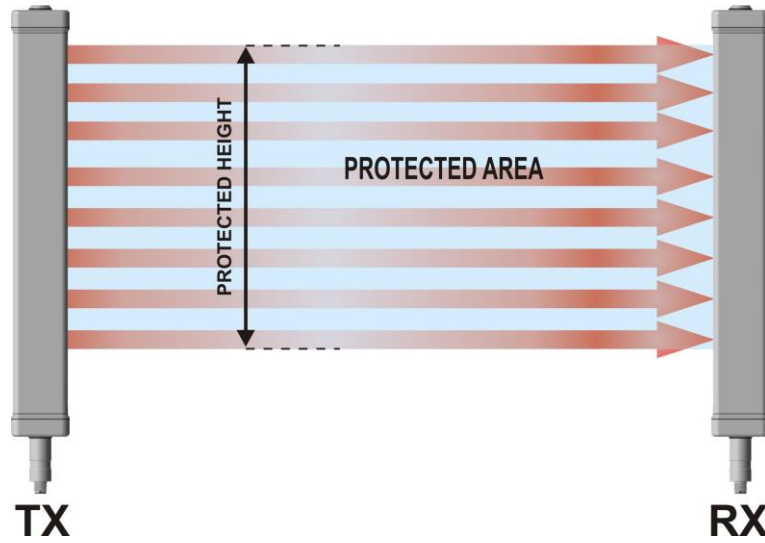
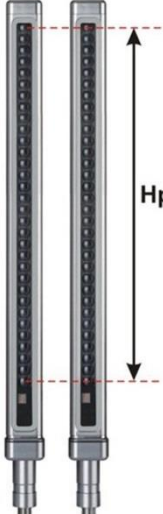

Fig 2 - Detection Zone

	MODEL	Controlled height Hp (mm)
	SG4-H14-015-OO-X-x	150
	SG4-H14-030-OO-X-x	300
	SG4-H14-045-OO-X-x	450

### 1.3.3 Minimum installation distance

The safety device must be positioned at a specific safety distance (**Fig 3 - page 10**).

This distance must ensure that the dangerous area cannot be reached before the dangerous motion of the machine has been stopped by the Safety Control System.

The safety distance depends on 4 factors, according to the EN ISO 13855 Standard:

- Response time of the ESPE (the time between the effective beam interruption and the opening of the OSSD contacts)
- Machine stopping time including Safety Control System computing and actuating time if present.
- ESPE resolution
- Approaching speed of the object to be detected

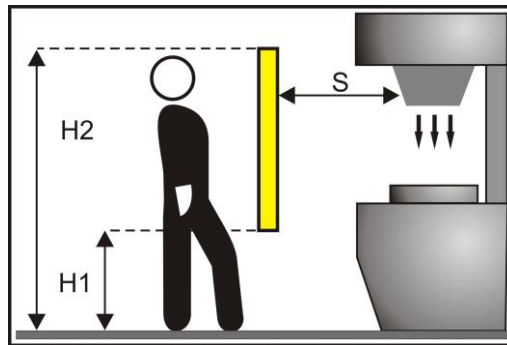

**Fig 3 - Installation distance (vertical positioning)**

The following formula is used for the calculation of the safety distance:

$$S = K (t1 + t2) + C$$

where:

- S = Minimum safety distance in mm
- K = Speed of the object, limb or body approaching the dangerous area in mm/sec
- t1 = Response time of the ESPE in seconds (see cfr. **TECHNICAL DATA page 36**)
- t2 = Machine stopping time in seconds (including the Safety Control System)
- C = Additional distance based on the possibility to insert the body or one of body parts inside the dangerous area before the protective device trips.  
 C=8 (R -14) for devices with resolution ≤ 40 mm  
 C=850 mm for devices with resolution > 40 mm
- R = Resolution of the system



**K value is:**  
**2000 mm/s if the calculated value of S is ≤ 500 mm**  
**1600 mm/s if the calculated value of S is > 500 mm**

When devices with > 40 mm resolution are used, the height of the top beam has to be ≥ 900 mm (H2) from machine supporting base while the height of the bottom beam has to be ≤ 300 mm (H1).

If the safety light curtain must be mounted in a horizontal position (**Fig 4 - page 11**) the distance between the dangerous area and the most distant optical beam must be equal to the value calculated using the following formula:

$$S = 1600 \text{ mm/s} (t1 + t2) + 1200 - 0,4 H$$

where:

- S = Minimum safety distance in mm.
- t1 = Response time of the ESPE in seconds (cfr. **TECHNICAL DATA page 36**)
- t2 = Machine stopping time in seconds (including the Safety Control System)
- H = Beam height from ground; this height must always be less than 1,000 mm.

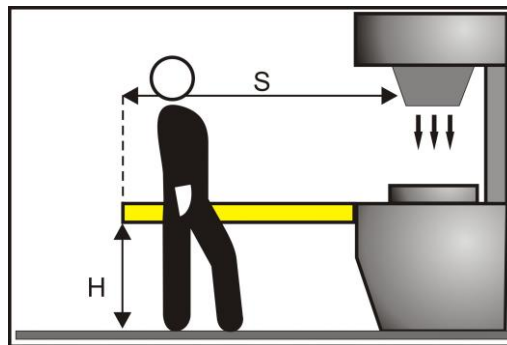

**Fig 4 - Installation distance (horizontal positioning)**

**Practical examples**

Let's suppose to have a light curtain with height = 600 mm

To calculate the distance of the device from the ESPE, in a vertical position, the following formula is used:

$$S = K * T + C$$

where:

- S = Minimum safety distance in mm.
- t1 = ESPE response time
- t2 = Machine total stopping time (Including safety control system).
- T = (t1 + t2) Overall system stopping performance
- C = 8 \* (R - 14) for devices with resolution ≤ 40 mm
- R = Resolution of the system

	SG4-H14-045-OO-X-x
T	0.398 sec
C	0 mm
S	636.8 mm



The reference standard is EN ISO 13855 "Safety of machinery - Positioning of safeguards with respect to the approach speeds of parts of the human body". The following information is to be considered as indicative and concise. For correct safety distance please refer to complete standard EN ISO 13855.

## 1.4 TYPICAL APPLICATIONS

Its unique mechanical features make SG4-H the best choice where safety light curtains have to be positioned inside an area where frequent washing with aggressive detergents and IP67 or IP69K are needed.

Typical applications are:

- **Liquid Filling Machines, used to fill bottles, ampoules and other containers with pre determined quantity of liquids.**
- **Vial Filling Machines, used to fill vials and bottles with liquids, viscous material, suspensions and powders.**
- **Powder filling machines.**

SG4-H can be placed within the machine area, i.e. in correspondence to the opening with gloves as seen in the picture.

The safety light curtain, realized in stainless steel and glass can stand the same level of washing of the rest of the machine ( i.e. hydrogen peroxide at high temperature and pressure).

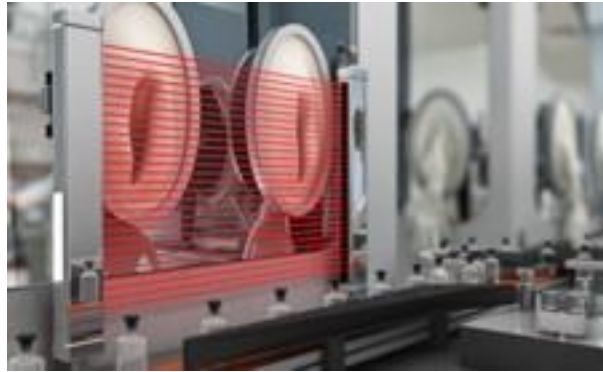

**Fig 5 - Filling machines**

## 1.5 SAFETY INFORMATION



For a correct and safe use of the safety light curtains, the following points must be observed:

- The stopping system of the machine must be electrically controlled.
- This control system must be able to stop the dangerous movement of the machine within the total machine stopping time T as per paragraph **Minimum installation distance page 10** and during all working cycle phases.
- Mounting and connection of the safety light curtain must be carried out by qualified personnel only, according to the indications included in the special sections (refer to sections **INSTALLATION page 14**, **MECHANICAL MOUNTING page 23**, **ELECTRICAL CONNECTIONS page 24**, **ALIGNMENT PROCEDURE page 27**) and in the applicable standards.
- The safety light curtain must be securely placed in a particular position so that access to the dangerous zone is not possible without the interruption of the beams (refer section **INSTALLATION page 14**).
- The personnel operating in the dangerous area must be well trained and must have adequate knowledge of all the operating procedures of the safety light curtain.



Please carefully read the instructions for the correct functioning before powering the light curtain on.

## 2 INSTALLATION

### 2.1 PRECAUTIONS TO BE OBSERVED FOR THE CHOICE AND INSTALLATION



Make sure that the protection level assured by the light curtain device is compatible with the real danger level of the machine to be controlled, according to EN ISO 13849-1: 2015 or EN 62061:2005/A2: 2015.

- Use only matched emitter and receiver pairs with same serial no.
- The outputs (OSSD) of the ESPE must be used as machine stopping devices and not as command devices.
- The machine must have its own START command.
- The dimension of the smallest object to be detected must be larger than the resolution level of the device.
- The ESPE must be installed in an environment complying with the characteristics indicated in **TECHNICAL DATA page 36**.
- The ESPE must not be installed close to strong and/or flashing light sources, in particular close to the front window of receiving unit.
- The presence of intense electromagnetic disturbances could affect device's correct operation.
- This condition shall be carefully assessed with the advice of DATALOGIC Technical Service.
- The operating distance of the device can be reduced in presence of smog, fog or airborne dust.
- A sudden change in environment temperature, with very low minimum peaks, can generate a small condensation layer on the lenses and thus jeopardize correct operation.
- Kind of mechanical fixation is suitable for vertical light curtain installation only.
- In such a case vibrations and bump limits on z-axis remains compliant according declared regulations (see cfr. **TECHNICAL DATA page 36**).

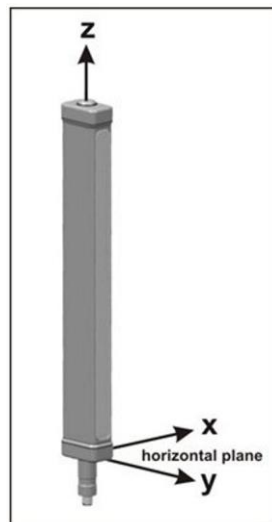

**Fig 6 - Vertical installation of the light curtain**

Keep mechanical environment as free as possible from all stress any case: if that is not possible, minimize the impact of mechanical stress on X and Y axes, i.e. re-aligning the light curtains in parallel to Z-axis.

## 2.2 GENERAL INFORMATION ON DEVICE POSITIONING

The safety light curtain should be carefully positioned in order to provide the necessary protection. Access to the dangerous area must only be possible by passing through the protecting safety light beams.



**Fig 7 - page 15 shows some examples of possible access to the machine from the top and the bottom sides. These situations may be very dangerous and so the installation of the safety light curtain at sufficient height in order to completely cover the access to the dangerous area (Fig 8 - page 15) becomes necessary.**

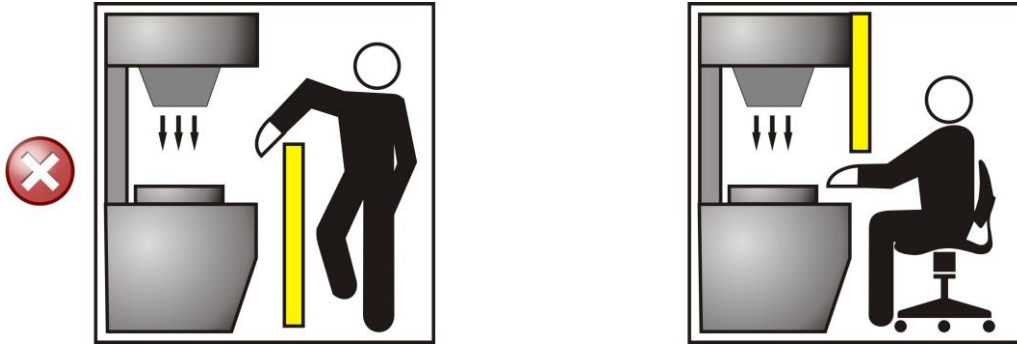

Fig 7 - Wrong light curtain positioning



Fig 8 - Correct light curtain positioning



**If the operator is able to enter in the dangerous area, an additional mechanical protection must be mounted to prevent the access.**

Under standard operating conditions, machine starting must not be possible while operators are inside the dangerous area.

Where it is not possible to install safety light curtain very near to the dangerous zone, a second light curtain must be mounted in a horizontal position in order to prevent any lateral access, as shown in Fig 10 - page 15.

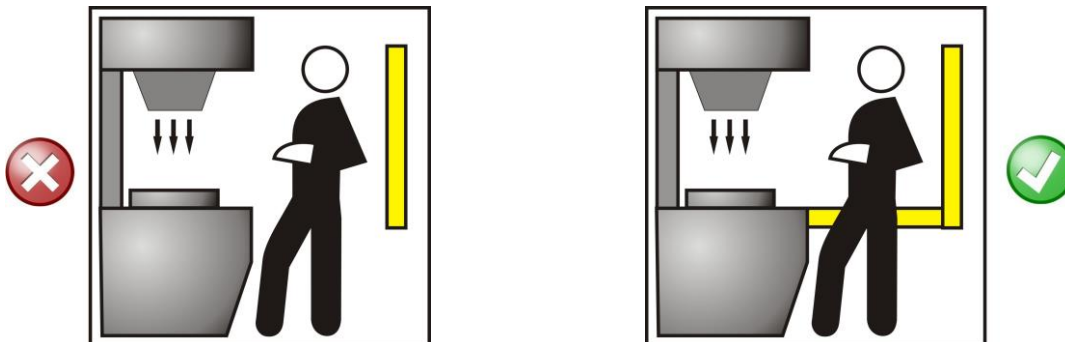
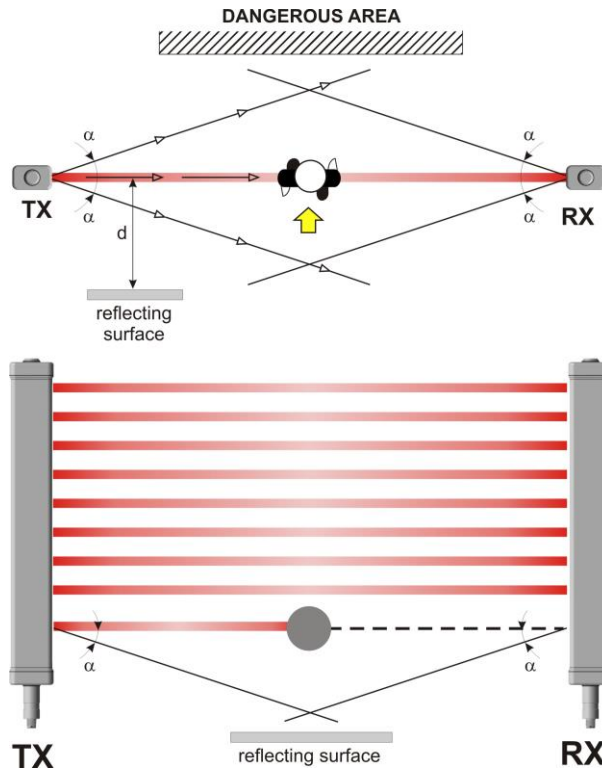

Fig 9 - Wrong light curtain positioning

Fig 10 - Correct light curtain positioning

### 2.2.1 Minimum distance from reflecting surfaces

Reflecting surfaces placed near the light beams of the safety device (over, under or laterally) can cause passive reflections. These reflections can affect the recognition of an object inside the controlled area. Moreover, if the RX receiver detects a secondary beam (reflected by the side-reflecting surface) the object might not be detected, even if the object interrupts the main beam.



**Fig 11 - Distances from reflective surfaces**

It is important to position the safety light curtain according to the minimum distance from reflecting surfaces.

The minimum distance depends on:

- operating distance between emitter (TX) and receiver (RX);
- real aperture angle of ESPE (EAA); especially:

**for ESPE Type 4 EAA = 5° ( $\alpha = \pm 2.5^\circ$ )**



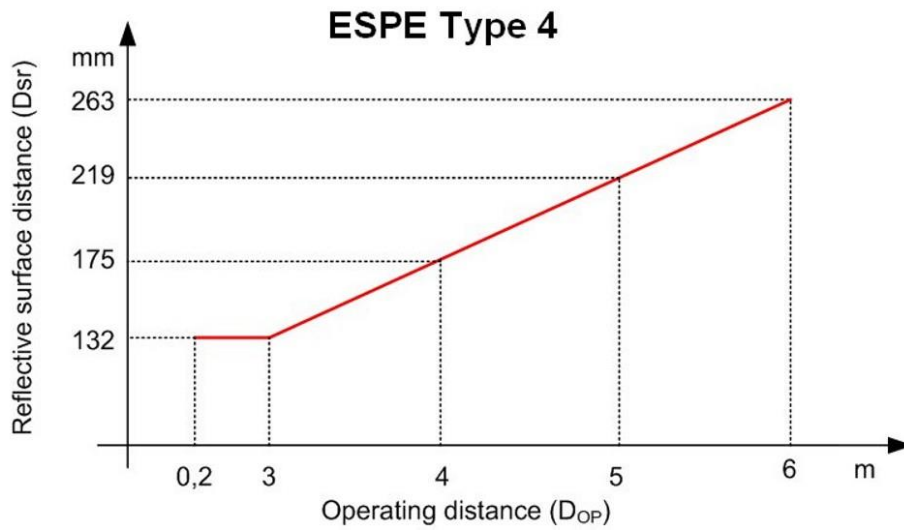

**Fig 12 - Minimum distance from reflective surface**

The formula to get Dsr is the following:

**For ESPE Type 4**

$D_{sr} (m) = 0.13$  for operating distance < 3 m

$D_{sr} (m) = 0.5 \times \text{operating distance (m)} \times \text{tg } 2\alpha$  for operating distance  $\geq 3$  m

### 2.2.2 Distance between homologous devices

The following graphic shows the distance from the interfering devices ( $D_{do}$ ) according to the operating distance ( $D_{op}$ ) of the couple (TXA – RXA).

If different safety devices have to be installed in adjacent areas, the emitter of one device must not interfere dangerously with the receiver of the other device.

The TXB interfering device must be positioned outside a minimum  $D_{do}$  distance from the TXA – RXA emitter-receiver couple axis.

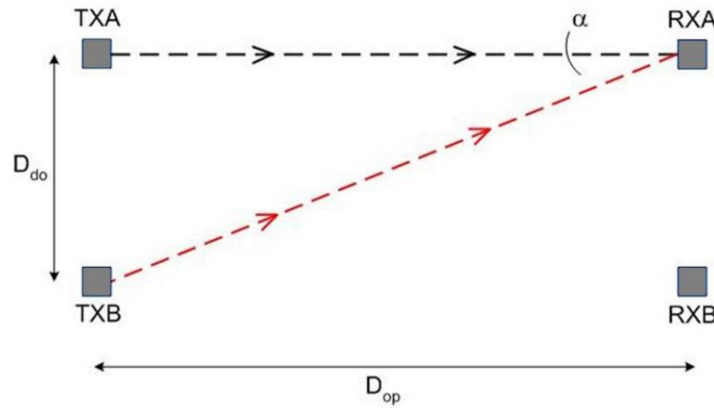

Fig 13 - Distance between homologous devices

This minimum  $D_{do}$  distance depends on:

- the operating distance between emitter (TXA) and receiver (RXA)
- the effective aperture angle of the ESPE (EAA)

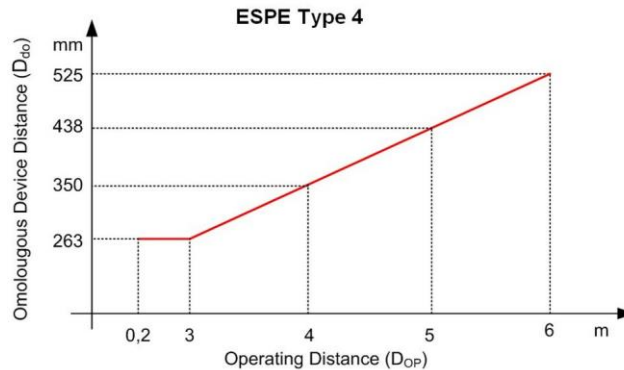

Fig 14 -

The following table shows, for convenience, the values of the minimum installation distances relative to some operating distances:

Operating distance (m)	Minimum installation distance (m)
3	0,3
6	0,4
10	0,5
19	0,6



**The interfering device (TXB) must be positioned at the same  $D_{do}$  distance, calculated as shown above, even if closer to TXA respect to RXA. Installation precautions have to be taken to avoid interference between homologous devices. A typical situation is represented by the installation areas of several adjacent safety devices aligned one next to the other, for example in plants with different machines.**

The figure provides two examples:

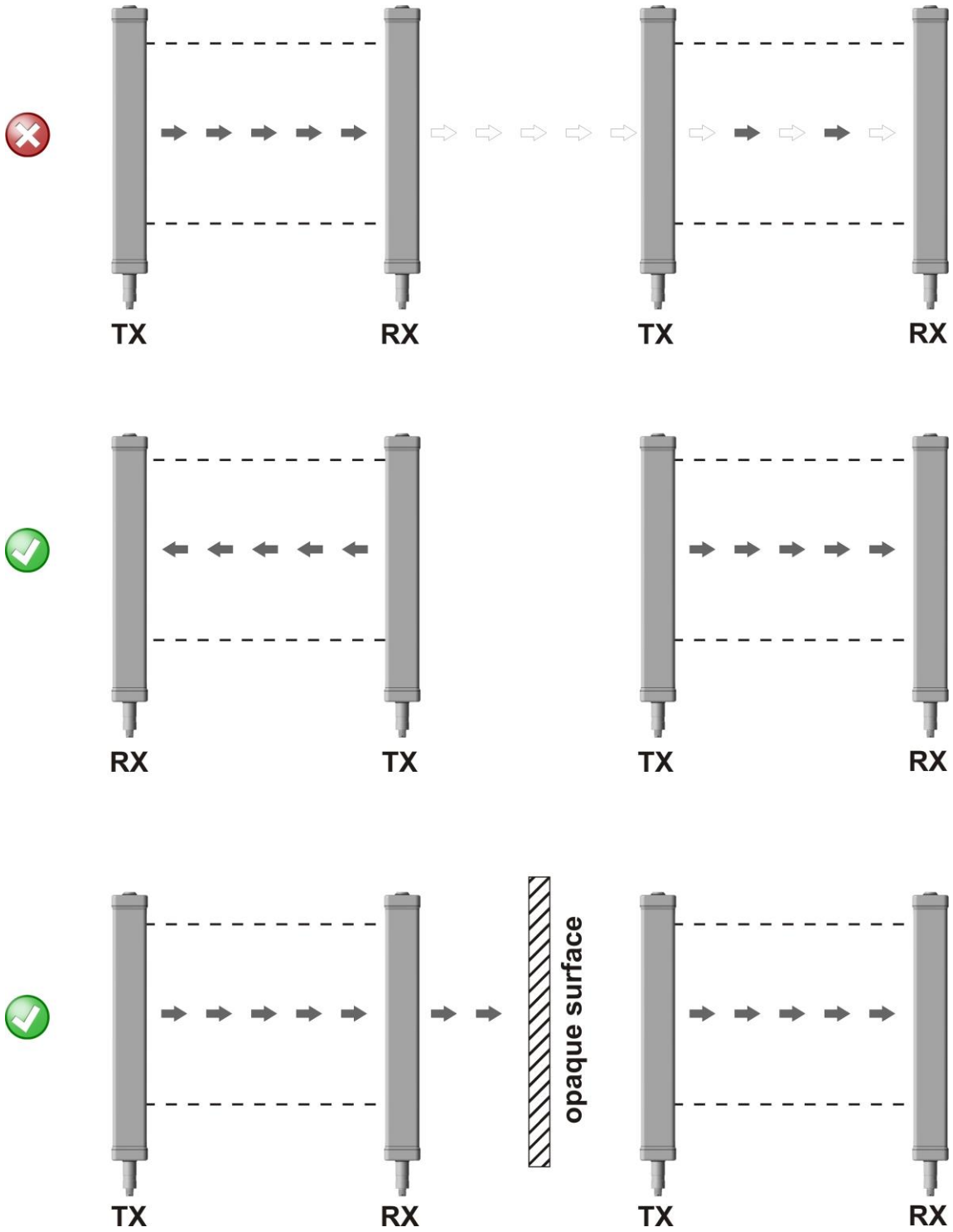

Fig 15 - Recommended positioning for homologous devices

### 2.2.3 Emitter and Receiver Orientation

The two units shall be assembled parallel each other, with the beams arranged at right angles with the emission and receiving surface, and with the connectors pointing to the same direction.

The configurations shown in the figure must be avoided:

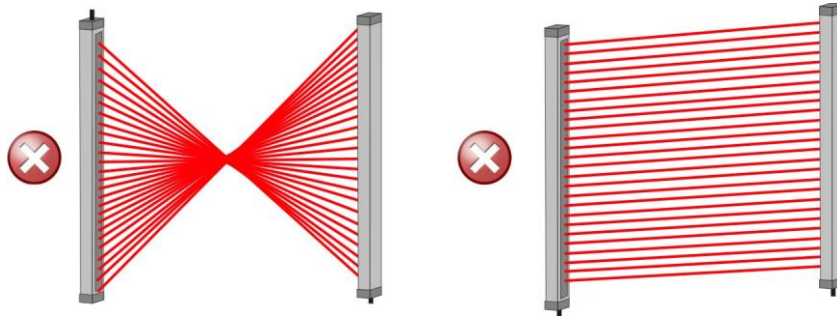

Fig 16 - Wrong light curtain TX-RX orientations

### 2.2.4 Use of deviating mirrors

The control of any dangerous area, with several but adjacent access sides, is possible using only one safety device and well-positioned deviating mirrors.

The figure shows a possible solution to control two different access sides, using one mirror placed at 45° with respect to the beams.

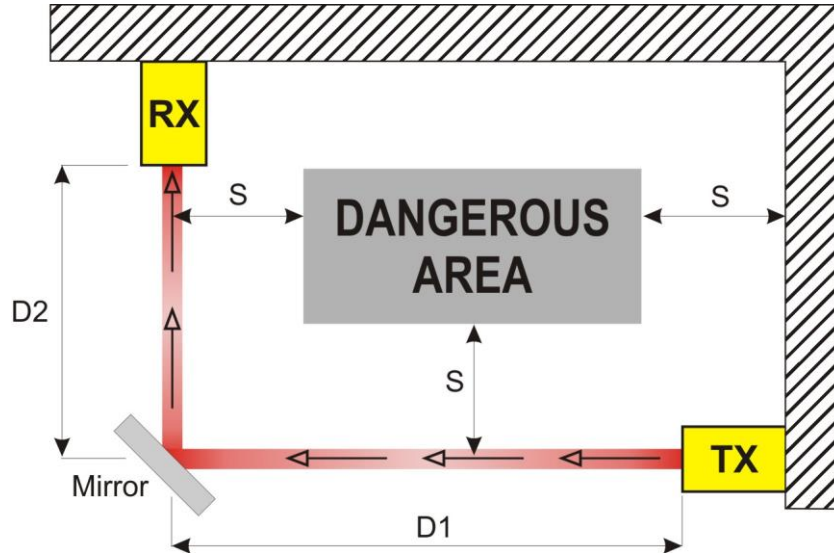

Fig 17 - Use of deviating mirrors

The operator must respect the following precautions when using the deviating mirrors:

- The alignment of the emitter and the receiver can be a very critical operation when deviating mirrors are used. Even very small displacements of the mirror is enough to lose alignment.
- The use of DATALOGIC laser pointer accessory is recommended under these conditions.
- The minimum safety distance (S) must be respected for each single section of the beams.
- The effective operating range decreases by about 20% by using only one deviating mirror.

The following table shows estimated operating distances relating to the number of mirrors used.

Number of mirrors	Operating Distance (14mm)
0	6.0 m
1	4.8 m

- The presence of dust or dirt on the reflecting surface of the mirror causes a drastic reduction in the range.

## 2.2.5 Controls after first installation

The control operations to carry-out after the first installation and before machine start-up are listed hereinafter. The controls must be carried-out by qualified personnel, either directly or under the strict supervision of the person in charge of machinery Safety.

Verify that:

- ESPE remains blocked (➤) intercepting the beams along the protected area using the specific test piece, following the **Fig 18 - page 22** scheme.

**TP14 for light curtains with 14 mm resolution:SG4-H14-xx-x**

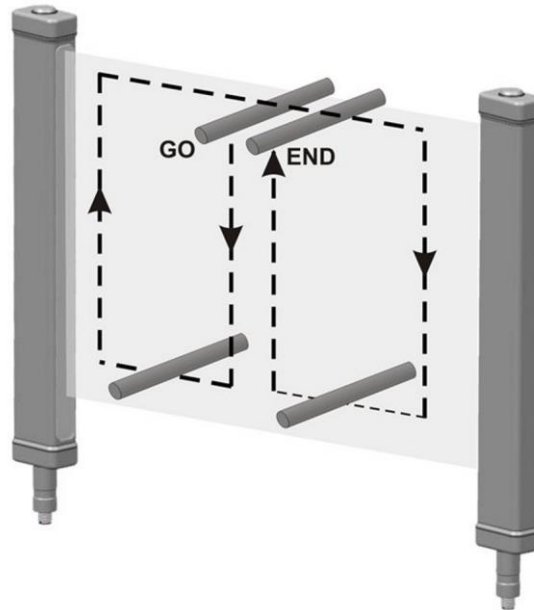

**Fig 18 - Path of the test piece**

- ESPE has to be correctly aligned, press slightly on the product side in both directions the red LED must not turn on ➤.
- The response time at machine STOP, including the ESPE and machine response times, must be included in the limits defined in the calculation of the safety distance (refer to chapter **INSTALLATION page 14**).
- The safety distance between the dangerous parts and ESPE must comply with the requirements indicated in chapter **INSTALLATION page 14**.
- A person must not access or remain between ESPE and the dangerous parts of the machine.
- Access to the dangerous areas of the machine must not be possible from any unprotected area.
- ESPE must not be disturbed by external light sources, ensuring that it remains in Normal operating function for at least 10-15 minutes and placing the specific test piece in the protected area in the SAFE condition for the same period.
- Verify the correspondence of all the accessory functions, activating them in the different operating conditions.

### 3 MECHANICAL MOUNTING

---

No mounting bracket is provided for this product

**SG4-H14-015-OO-X-B / SG4-H14-030-OO-X-B / SG4-H14-045-OO-X-B**

The product is equipped with a support shaft exiting at connector area and designed to allow vertical and coaxial fastening on one side only.

It is a simple and safe fastening that makes product position adjustable around the longitudinal axis.

This type of fastening reduces the number of applications where light curtains are mounted **vertically** and vibration limits on z-axes are compliant to declared regulation accordingly (see cfr. **TECHNICAL DATA page 36**).

**SG4-H14-015-OO-X-G / SG4-H14-030-OO-X-G / SG4-H14-045-OO-X-G**

The product is equipped with two support shafts exiting at connector area and opposite area designed to allow horizontal, vertical and coaxial fastening on both side.

It is a simple and safe fastening that makes product position adjustable around the longitudinal axis.

This type of fastening reduces the number of applications where light curtains are mounted **horizontally** and vibration limits on z-axes are compliant to declared regulation accordingly (see cfr. **TECHNICAL DATA page 36**).

## 4 ELECTRICAL CONNECTIONS

### 4.1 PIN-OUT AND CONFIGURATION PIN CONNECTION

All electrical connections to the emitting and receiving units are made through a male M12 connector, located on the lower part of the two units.

For receiver a M12 5-poles connector is used, while for emitter a M12 4-poles connector is used.

**RECEIVER (RX):**

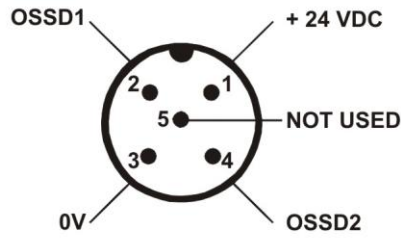

Fig 19 - Receiver

- |     |       |            |
|-----|-------|------------|
| 1 = | brown | = +24 VDC  |
| 2 = | white | = OSSD1    |
| 3 = | blue  | = 0 V      |
| 4 = | black | = OSSD2    |
| 5 = | grey  | = NOT USED |

**EMITTER (TX):**

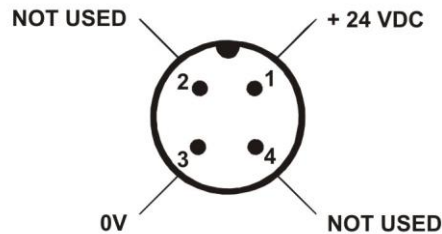

Fig 20 - Emitter

- |     |       |            |
|-----|-------|------------|
| 1 = | brown | = +24 VDC  |
| 2 = | white | = NOT USED |
| 3 = | blue  | = 0 V      |
| 4 = | black | = NOT USED |



## 4.2 NOTES ON CONNECTIONS

For the correct operation of the safety light curtains, the following precautions regarding the electrical connections have to be respected:

- Do not place connection cables in contact with or near high-voltage cables and/or cable undergoing high current variations (e.g. motor power supplies, inverters, etc.).
- The device is already equipped with internal overvoltage and overcurrent suppression devices.
- **The use of other external components is not recommended.**

### Example: connection to the safety relay SE-SR2

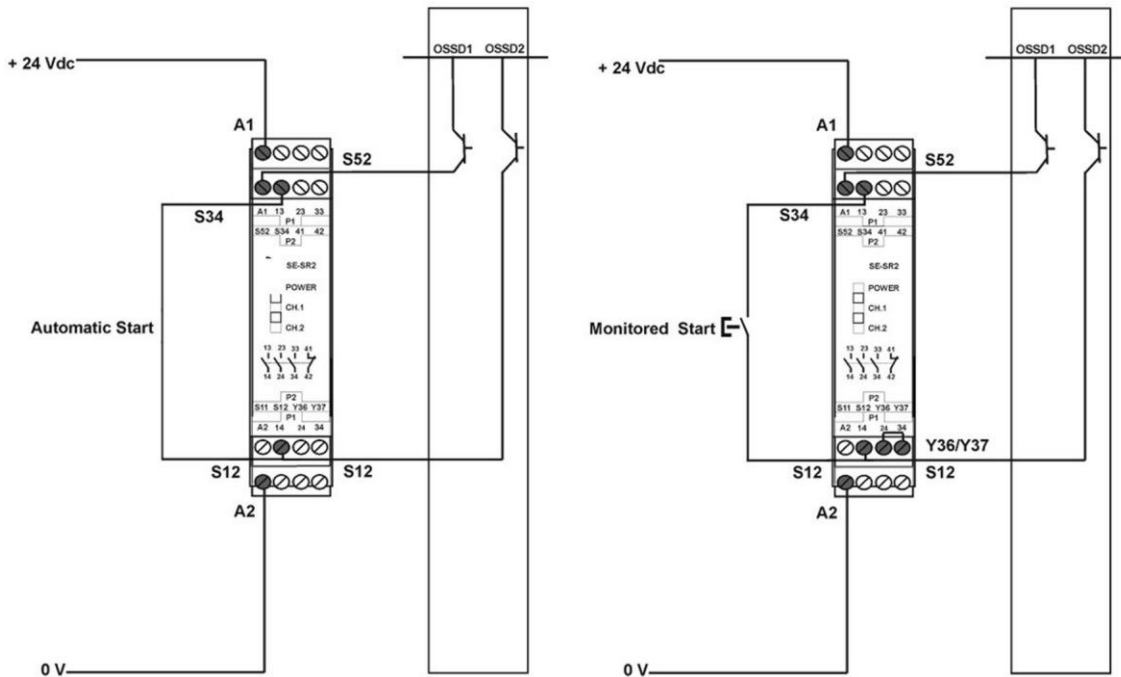
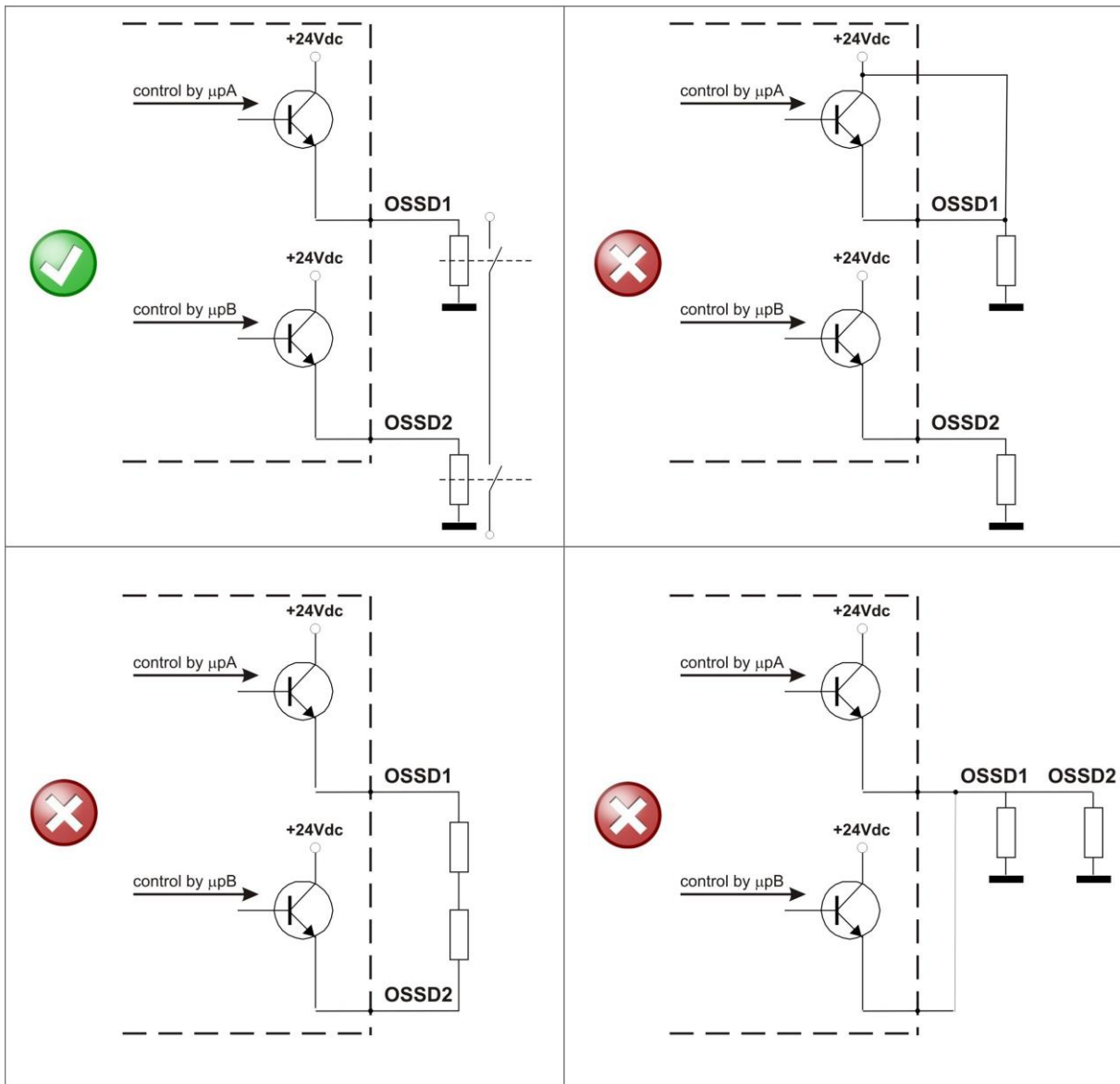

Fig 21 - Connection to SE-SR2 Safety Relays

The figures show the connection between the safety light curtains and the safety relay of the SE-SR2 series functioning in the Automatic Restart mode (left side) and Manual Restart with monitoring (right side).

- Do not use varistors, RC circuits or LEDs in parallel at relay inputs or in series at OSSD outputs.
- The OSSD1 and OSSD2 safety contacts cannot be connected in series or in parallel, but can be used separately, conforming to the plant's safety requirements.
- If one of these configurations is erroneously used, the device enters into the output failure condition (see cfr. **USER INTERFACE AND DIAGNOSTICS page 30**).

- Connect both OSSDs to the device to control.
- Failure to connect an OSSD to the activating device jeopardizes the system safety degree that the light curtain has to control.



**Fig 22 - OSSDs connection**

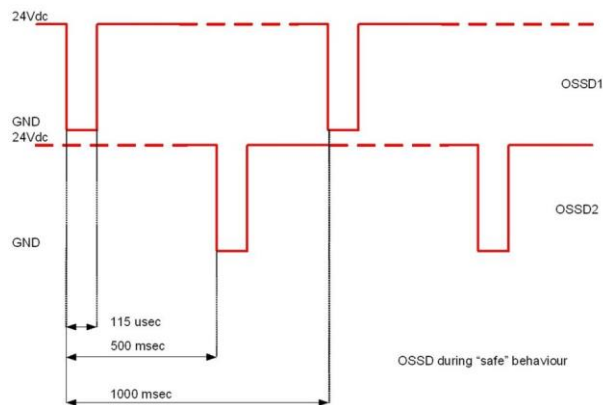

**Fig 23 - Behaviour of OSSDs**

## 5 ALIGNMENT PROCEDURE

The alignment between the emitting and the receiving units is necessary to obtain the correct operation of the light curtain.

A good alignment prevents outputs instability caused by dust or vibrations.

The alignment is perfect if the optical axes of the first and the last emitting unit's beams coincide with the optical axes of the corresponding elements of the receiving unit.

The beam used to synchronise the two units is the closest one to the connector.

SYNC is the optics connected with this beam and LAST is the optics connected to the last beam after the SYNC unit.

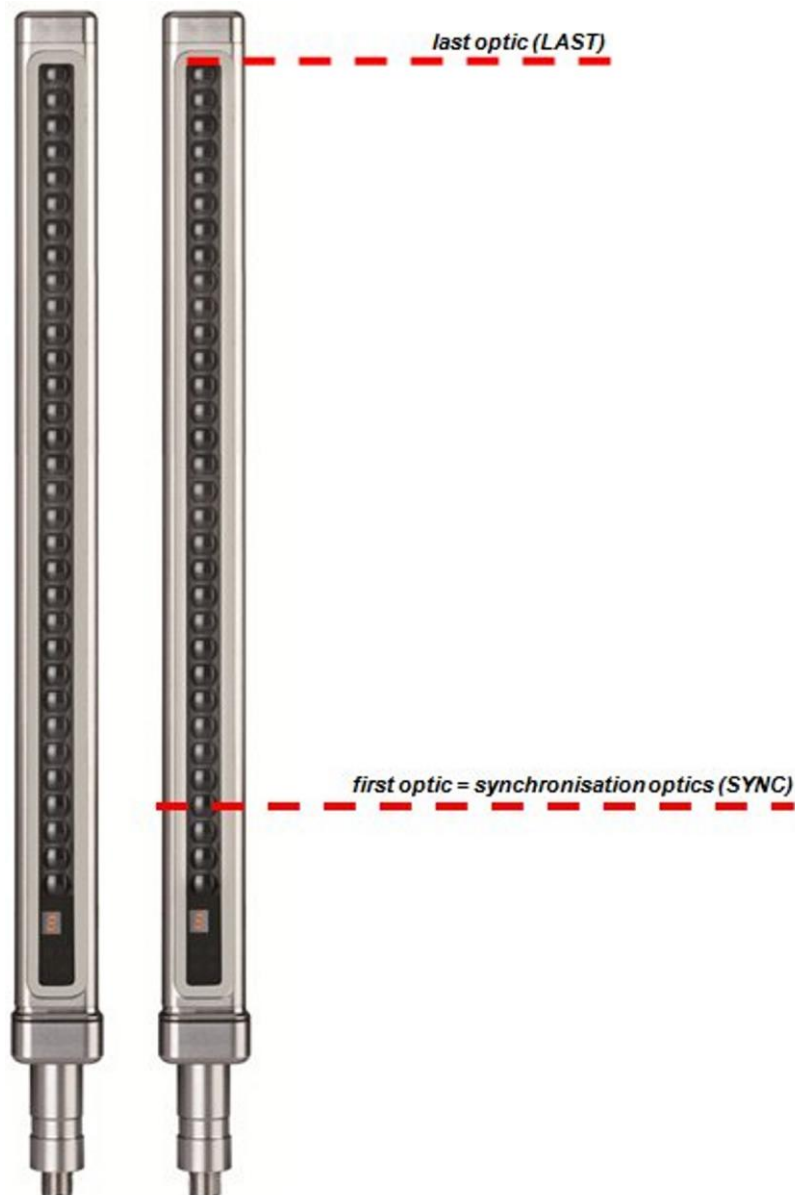

Fig 24 - SYNC optics

Signals are clearly identified through symbols allowing their immediate reading, independent of bars directions; a short description of LEDs signals proves nevertheless necessary so as to avoid misunderstandings.



Fig 25 - LEDs signals

The alignment level is monitored during device standard operating mode via display (see **Diagnostic messages page 30**).

Once the curtain has been aligned and correctly fastened, the display signal is useful both to check the alignment and show a change in the environmental conditions (occurrence of dust, light disturbance and so on) via signal level monitoring.

## 6 FUNCTIONS SETTING

---

Light curtains is ready to use without any preliminary function setting.

Light curtain, starts up end goes in normal operation as soon as connected to power supply.

Check connection for any improper detected start up.

## 7 USER INTERFACE AND DIAGNOSTICS

### 7.1 USER INTERFACE

Curtain operating status is visualised through an one-digit display present on both the receiver and emitter units.

SG4-H also has four LEDs on the receiver and two LEDs on the emitter.

**Fig 26 - page 30** shows all LEDs signalling modes: OFF, ON and BLINKING.



**Fig 26 - LEDs signalling modes**







## 7.2 DIAGNOSTIC MESSAGES

The operator can evaluate the main causes of the system stop or failure through the display and signalling LEDs.

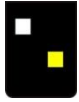
**For Receiver:**

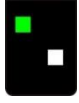
Function	Type	Check and repair	LED	DIGIT
	Emission (OSSD ON) (green ON)	Light curtain working in normal operating conditions		
	Interruption (OSSD OFF) (red ON)	Light curtain working in safety block conditions.		
	Signal level	Minimum (1 bar) Medium (2 bar) Maximum (3 bar)		
Function	Type	Check and repair	LED	DIGIT
Error status	OSSD error (red ON)	Check OSSD connections. Make sure that they are not in contact with one another or with the supply cables, then Reset. If the failure continues contact DATALOGIC.		
	Internal error (red ON)	Switch OFF and switch ON the power supply circuit. If the failure continues contact DATALOGIC.		
	Optical error (red ON)	Reset. If the failure continues contact DATALOGIC.		
	No power supply (LEDs OFF)	Check connections and input voltage value. If the failure continues contact DATALOGIC.		

**For Emitter:**

Function	Type	Check and repair	LED	DIGIT
	Emission (green ON, yellow ON)	Light curtain in normal operating condition		
Function	Type	Check and repair	LED	DIGIT
Error status	Internal error (green ON)	Switch OFF and switch ON the power supply circuit. If the failure continues contact DATALOGIC		
	Optical error (green ON)			
	No power supply (LEDs OFF)	Check connections and input voltage correct value. If the failure continues contact DATALOGIC		



## 8 PERIODICAL CHECKS

---

The following is a list of recommended check and maintenance operations that should be periodically carried-out by qualified personnel (cfr. **Controls after first installation page 21**)

Check that:

- The ESPE stays locked (➤) during beam interruption along the entire protected area, using the suitable "Test Piece" (see **Fig 18 - page 22**)
- The ESPE is correctly aligned. Press slightly product side, in both directions and the red LED ( ) must not turn ON.
- The response time upon machine STOP (including response time of the ESPE and of the machine) is within the limits defined for the calculation of the safety distance (see section **INSTALLATION page 14**).
- The safety distance between the dangerous areas and the ESPE are in accordance with the instructions included in section **INSTALLATION page 14**.
- Access of a person between ESPE and machine dangerous parts is not possible nor is it possible for him/her to stay there.
- Access to the dangerous area of the machine from any unprotected area is not possible.
- The ESPE and the external electrical connections are not damaged.

The frequency of checks depends on the particular application and on the operating conditions of the safety light curtain.

Verify that:

ESPE remains blocked (➤) intercepting the beams along the protected area using the specific test piece, following the **Fig 18 - page 22** scheme.

**TP14 for light curtains with 14 mm resolution:**

**SG4-H14-xx-x**

## 8.1 GENERAL INFORMATION AND USEFUL DATA



**Safety MUST be a part of our conscience.**

The safety devices fulfil their safety function only if they are correctly installed, in accordance with the Standards in force.

If you are not certain to have the expertise necessary to install the device in the correct way, DATALOGIC is at your disposal to carry out the installation.

The device uses fuses that are not self-resetting. Consequently, in presence of short-circuits causing the cut-off of these fuses, both safety light curtains (RX and TX) shall be sent to DATALOGIC Repair Service Department.

A power failure caused by interferences may cause the temporary or trigger Safety State over connected safety Fieldbus, but the safe functioning of the light curtain will not be compromised.

## 8.2 WARRANTY

The warranty period for this product is 36 months.

See the General Terms and Conditions of Sales at [www.datalogic.com](http://www.datalogic.com) for further details.

DATALOGIC will not be liable for any damages to persons and things caused by the non-observance of the correct installation modes and device use.

In presence of a non-functioning device, always return the emitting and receiving units for repair or replacement.

## 9 DEVICE MAINTENANCE

---

DATALOGIC safety light curtains do not require special maintenance operations.

To avoid the reduction of the operating distance, optic protective front surfaces must be cleaned at regular intervals.

Use soft cotton cloths dampened in water.

Do not apply too much pressure on the surface in order to avoid making it opaque.

Please do not use on plastic surfaces or on light curtain painted surfaces:

- **alcohol or solvents**
- **wool or synthetic cloths**
- **paper or other abrasive materials**

### 9.1 PRODUCT DISPOSAL

Under current Italian and European laws, DATALOGIC is not obliged to take care of product disposal at the end of its life.

DATALOGIC recommends to dispose of the product in compliance with local laws or contact authorised waste collection centres.

## 10 TECHNICAL DATA

<b>SAFETY CATEGORY:</b>	Type 4 (rif. EN 61496-1: 2013)
	SIL 3 (rif. EN 61508)
	SIL CL 3 (ref. EN 62061:2005/A2: 2015)
	PL e, Cat. 4 (rif. EN ISO 13849-1: 2015)
	PFHd [1/h] = 2,64E-09
	MTTFd [years] = 444

<b>ELECTRICAL DATA</b>	
Power supply (Vdd):	24 VDC $\pm$ $\pm$ 20%
Consumption (TX):	2.5 W max
Consumption (RX):	3.5 W max (without load)
Outputs:	2 PNP
Short-circuit protection:	1.4 A max
Output current:	0.5 A max / each output
Output voltage – status ON:	Vdd –1 V min
Output voltage – status OFF:	0.2 V max
Capacitive load	2.2 $\mu$ F @ 24 VDC max
Response times:	See table below
Controlled height:	150..450 mm
Electrical protection:	Class III
Connections:	M12 4-pole for emitter M12 5-pole for receiver
Cable length (for power supply):	50 m max

<b>OPTICAL DATA</b>	
Light emission (I):	Infrared, LED (950 nm)
Resolution:	14 mm
Operating distance:	0.2...6 m
Ambient light rejection:	EN 61496-2: 2013

<b>MECHANICAL AND ENVIRONMENTAL DATA</b>	
Operating temperature:	- 10°...+ 55 °C
Storage temperature:	- 25°...+ 70 °C
Temperature class:	T6
Humidity:	15...95 % (no condensation)
Mechanical protection:	IP65 (EN 60529) / IP69K
Vibrations *:	Width 0.35 mm, Frequency 10 ... 55 Hz 20 sweep per z-axis, 1 octave/min (EN 60068-2-6)
Shock resistance:	16 ms (10 G) 1,000 shocks per z-axis (EN 60068-2-29)
Housing and Cap material:	AISI 316L
Front glass material:	Glass
Weight:	3.5 Kg / meter for each single unit

## 11 AVAILABLE MODELS

Model	Controlled height (mm)	No. Beams	Response time (msec)	Resolution (mm)
SG4-H14-015-OO-X-x	150	16	11	14
SG4-H14-030-OO-X-x	300	32	15	14
SG4-H14-045-OO-X-x	450	48	18	14

Product	EN ISO 13849-1				Prob. of danger failure/hour	Life span	Mean Time to Dangerous Failure	Average Diagnostic Coverage	Safe Failure Fraction	Hardware Fault Tolerance
	PL	CAT	SIL	SIL CL						
SG4-H14-015-OO-X-x	e	4	3	3	2.64E-09	20	444	98.80%	99.30%	1
SG4-H14-030-OO-X-x	e	4	3	3	2.64E-09	20	444	98.80%	99.30%	1
SG4-H14-045-OO-X-x	e	4	3	3	2.64E-09	20	444	98.80%	99.30%	1

## 12 OVERALL DIMENSIONS

SG4-H14-015-OO-X-B / SG4-H14-030-OO-X-B / SG4-H14-045-OO-X-B

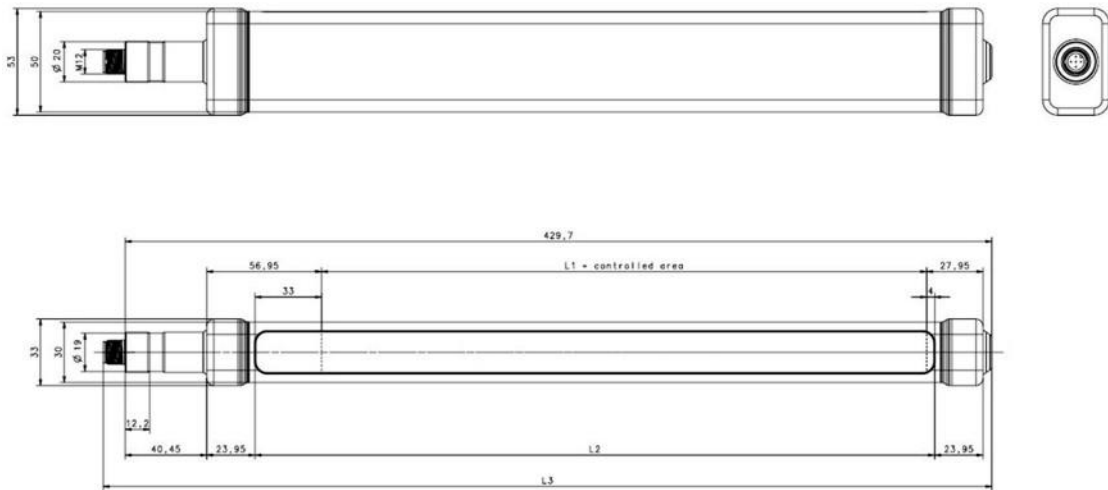

Fig 27 - Overall dimensions (mm)

	SG4-H14-015-OO-X-B	SG4-H14-030-OO-X-B	SG4-H14-045-OO-X-B
L1	150	300	450
L2	187	337	487
L3	290.6	440.6	590.6

SG4-H14-015-OO-X-G / SG4-H14-030-OO-X-G / SG4-H14-045-OO-X-G



Fig 28 - Overall dimensions (mm)

	SG4-H14-015-OO-X-G	SG4-H14-030-OO-X-G	SG4-H14-045-OO-X-G
L1	150	300	450
L2	187	337	487
L3	302.3	452.3	602.3

## 13 ACCESSORIES

---

### 13.1 (TP) TEST PIECE

MODEL	DESCRIPTION	CODE
TP-14	Test piece Ø 14mm L=300mm	95ACC1630
TP-20	Test piece Ø 20mm L=300mm	95ACC1640
TP-24	Test piece Ø 24mm L=200mm	95ASE2570
TP-30	Test piece Ø 30mm L=300mm	95ACC1650
TP-34	Test piece Ø 34mm L=200mm	95ASE2580
TP-35	Test piece Ø 35mm L=300mm	95ACC1660
TP-40	Test piece Ø 40mm L=300mm	95ACC1820
TP-50	Test piece Ø 50mm L=300mm	95ACC1790
TP-90	Test piece Ø 90mm L=300mm	95ACC1800

## 13.2 CONNECTION CABLES

### 4-pole M12 cables

MODEL	DESCRIPTION	CODE
CS-A1-02-U-03	4-pole M12 cable (axial) 3 m	95ASE1120
CS-A1-02-U-05	4-pole M12 cable (axial) 5 m	95ASE1130
CS-A1-02-U-10	4-pole M12 cable (axial) 10 m	95ASE1140
CS-A1-02-U-15	4-pole M12 cable (axial) 15 m	95ASE1150
CS-A1-02-U-25	4-pole M12 cable (axial) 25 m	95ASE1160

### 5-pole M12 cables

MODEL	DESCRIPTION	CODE
CS-A1-03-U-03	5-pole M12 cable (axial) 3 m UL2464	95ASE1170
CS-A1-03-U-05	5-pole M12 cable (axial) 5 m UL2464	95ASE1180
CS-A1-03-U-10	5-pole M12 cable (axial) 10 m UL2464	95ASE1190
CS-A1-03-U-15	5-pole M12 cable (axial) 15 m UL2464	95ASE1200
CS-A1-03-U-25	5-pole M12 cable (axial) 25 m UL2464	95ASE1210
CS-A1-03-U-50	5-pole M12 cable (axial) 50 m UL2464	95A252700



### 13.3 (SE-SR2) SAFETY RELAY

MODEL	DESCRIPTION	CODE
SE-SR2	Type 4 safety relay - 3 NQ 1 NC	95ACC6170

The drawing show the connection between the safety light curtain and the Type 4 safety relay of the SE-SR2 series operating in the automatic Restart mode.

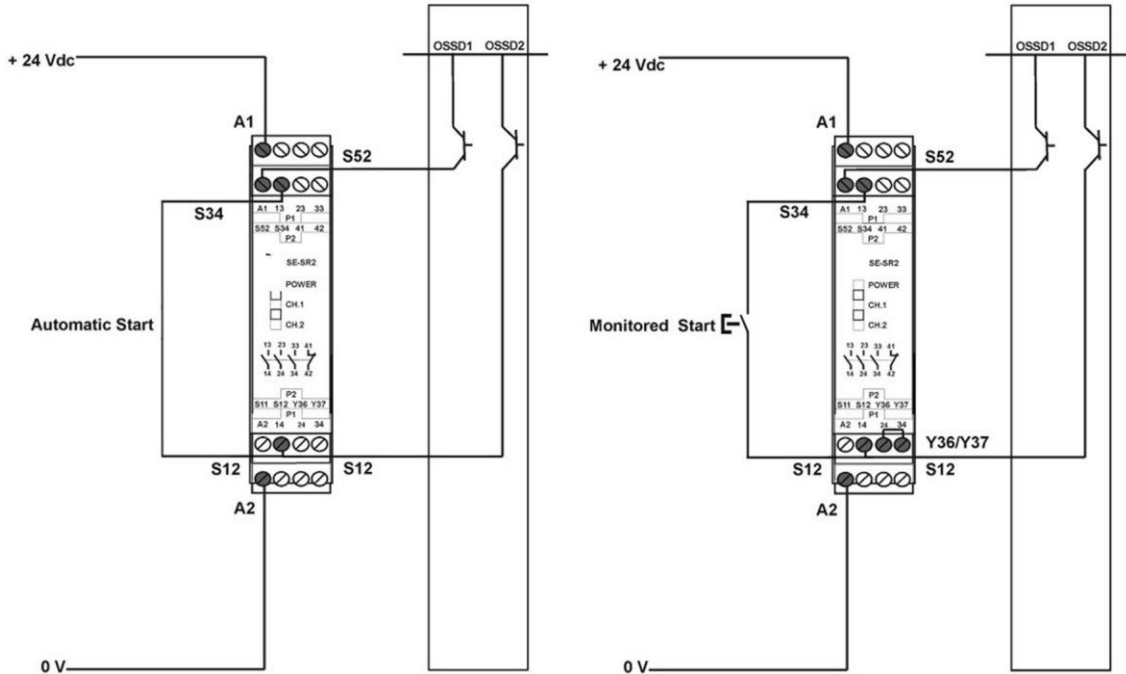

Fig 29 - Safety relay

## 14 GLOSSARY

---

**Detection zone:** zone within which a specified test piece will be detected by the ESPE

**Safety light curtain:** it is an active optoelectronic protective device (AOPD) including an integrated system consisting of one or several emitting elements and one or several receiving elements forming a detection area with a detecting capacity specified by the supplier.

**Detection capability (or Resolution):** the minimum dimension which an opaque object must have in order to interrupt at least one beams of the ESPE whatever is position across the protected height.

**Force-guided contacts:** Relay contacts are force guided when they are mechanically connected so that they must switch simultaneously on input change.

If one contact of the series remains “welded”, no other relay contact is able to move.

That relay characteristic allows the use of EDM function.

**OSSD (Output signal switching device):** part of the ESPE connected to machine control system.

When the sensor is enabled during standard operating conditions, it switches to disabled status.

**ESPE (Electro-sensitive protective equipment):** assembly of devices and/or components working together to activate the protective disabling function or to detect the presence of something and including at least: a sensor, command/control devices and output signal switching devices.

**AOPD (Active optoelectronic protective device):** its detection function is achieved thanks to the use of optoelectronic receivers and emitters detecting the optical beams interruptions inside the device caused by an opaque object present inside the specified detecting area.

An active optoelectronic protective device (AOPD) can operate both in emitter-receiver mode and in retro-reflective light curtains.

**Protective device:** device having the function to protect the operator against possible risks of injury due to the contact with machine potentially-dangerous parts.

**Min.installation distance:** min. distance necessary to allow machine dangerous moving parts to completely stop before the operator can reach the nearest dangerous point. This distance shall be measured from the middle point of the detecting area to the nearest dangerous point. Factors affecting min. installation distance value are machine stop time, total safety system response time and light curtain resolution.

**EDM (External device monitoring):** device used by the ESPE to monitor the status of the external command devices.

**MPCE (Machine primary control element):** electrically-powered element having the direct control of machine regular operation so as to be the last element, in order of time, to operate when the machine has to be enabled or blocked.

**Emitter (TX):** unit emitting infrared beams, consisting of a set of optically-synchronised LEDs. The emitting unit, combined with the receiving unit (installed in the opposite position), generates an optical “curtain”, i.e. the detecting area.

**Restart interlocking device (=RESTART):** device preventing machine automatic restart after sensor activation during a dangerous phase of machine operating cycle, after a change of machine operating mode, and after a variation in machine start control devices.

**Start interlocking device (= START):** device preventing machine automatic start if the ESPE is live or the voltage is disabled and enabled once again.

**Interlock:** operating state of ESPE in Manual Restart Mode when all beams are free but the Restart command hasn't been received yet.

**Normal Operation:** operating state of ESPE when all beams are free, OSSD LED lit GREEN in SL light curtain OSSD1 and OSSD2 are switchen ON.

**N.O.:** normally opened

**N.C.:** normally closed

**Machine operator:** qualified person allowed to use the machine.

**Qualified operator:** a person who holds a professional training certificate or having a wide knowledge and experience and who is acknowledged as qualified to install and/or use the product and to carry out periodical test procedures.

**Working point:** machine position where the material or semifinished product is worked.

**Receiver (RX):** unit receiving infrared beams, consisting of a set of optically-synchronised phototransistors. The receiving unit, combined with the emitting unit (installed in the opposite position), generates an optical "curtain", i.e. the detecting area.

**Crossing hazard:** situation under which an operator crossing the area controlled by the safety device and this latter stops and keeps the machine stopped until the hazard is eliminated, and then enters the dangerous area. Now the safety device could not be able to prevent or avoid an unexpected restart of the machine with the operator still present inside the dangerous area.

**Risk:** probability of occurrence of an injury and severity of the injury itself.

**Block condition (=BREAK):** status of the light curtain taking place when a suitably-sized opaque object (see cfr.XREF-1:313) interrupts one or several light curtain beams.

Under these conditions, OSSD1 and OSS2 light curtain outputs are simultaneously switched OFF within the device response time.

**Safe State:** operating state of ESPE when at least one beam is intercepted, OSSD LED lit RED in [INLINE-1:44 light curtain. OSSD1 and OSSD2 are both switched OFF.

**Response time:** maximum time between the occurrence of the event leading to the actuation of the sensing device and the output signal switching devices (OSSD) achieving the OFF-state

**Test piece:** opaque object having a suitable size and used to test safety light curtain correct operation.

**Type (of ESPE):** the Electro-sensitive Protective Equipment (ESPE) have different reactions in case of faults or under different environmental conditions.

The classification and definition of the "type" (ex. type 2, type 4, according to EN 61496-1: 2013) defines the minimum requirements needed for ESPE design, manufacturing and testing.

**Dangerous area:** area representing an immediate or imminent physical hazard for the operator working inside it or who could get in contact with it.

Fig 1 - Detection capability ..... 8

Fig 2 - Detection Zone..... 9

Fig 3 - Installation distance (vertical positioning)..... 10

Fig 4 - Installation distance (horizontal positioning) ..... 11

Fig 5 - Filling machines ..... 12

Fig 6 - Vertical installation of the light curtain..... 14

Fig 7 - Wrong light curtain positioning..... 15

Fig 8 - Correct light curtain positioning..... 15

Fig 9 - Wrong light curtain positioning ..... 15

Fig 10 - Correct light curtain positioning..... 15

Fig 11 - Distances from reflective surfaces ..... 16

Fig 12 - Minimum distance from reflective surface ..... 17

Fig 13 - Distance between homologous devices ..... 18

Fig 14 - ..... 18

Fig 15 - Recommended positioning for homologous devices..... 19

Fig 16 - Wrong light curtain TX-RX orientations..... 20

Fig 17 - Use of deviating mirrors ..... 21

Fig 18 - Path of the test piece ..... 22

Fig 19 - Receiver..... 24

Fig 20 - Emitter ..... 24

Fig 21 - Connection to SE-SR2 Safety Relais..... 25

Fig 22 - OSSDs connection..... 26

Fig 23 - Behaviour of OSSDs..... 26

Fig 24 - SYNC optics ..... 27

Fig 25 - LEDs signals..... 28

Fig 26 - LEDs signalling modes ..... 30

Fig 27 - Overall dimensions (mm) ..... 38

Fig 28 - Overall dimensions (mm) ..... 38

Fig 29 - Safety relay ..... 41



 **DATALOGIC**

---

[www.datalogic.com](http://www.datalogic.com)