

# SAFETY LIGHT CURTAIN LP4

## SUMMARY

<b>INTRODUCTION .....</b>	<b>2</b>
<b>PRINCIPLE OF OPERATION .....</b>	<b>3</b>
<b>LIGHT CURTAIN .....</b>	<b>3</b>
<b>MUTING FUNCTION .....</b>	<b>4</b>
LP4ER_M model- external sensors 3 selectable methods of Muting.....	4
LP4ER_M models used with “L” operational logic .....	6
<b>INSTALLATION .....</b>	<b>6</b>
<b>POSITIONING .....</b>	<b>8</b>
POSITIONING OF THE MUTING SENSORS (“LP4ER_M” SERIES).....	8
CALCULATION OF THE SAFETY DISTANCE .....	10
VERTICAL POSITIONING OF THE LIGHT CURTAIN .....	11
MULTIPLE SYSTEMS .....	13
DISTANCE FROM REFLECTIVE SURFACES.....	13
<b>LIGHT SIGNALS.....</b>	<b>15</b>
Emitter SIGNALS .....	15
Receiver SIGNALS.....	16
<b>ELECTRICAL CONNECTIONS AND CONNECTORS .....</b>	<b>18</b>
EMITTER CONNECTIONS (Male Connector) .....	18
RECEIVER CONNECTIONS (Main Connector - Male) .....	19
CONNECTOR M12 n. 1 (for muting sensor) (“LP4ER_M” MODELS) (Female Connector) .....	20
CONNECTOR M12 n. 2 (for muting sensor) (“LP4ER_M” MODELS) (Female Connector) .....	20
RECEIVER CONNECTIONS J LR M12 MODELS.....	21
<b>SELECTION OF CONFIGURATION AND OPERATING MODE .....</b>	<b>21</b>
SELECTION FEEDBACK EXTERNAL CONTACTORS K1/K2.....	21
SELECTION OF MANUAL/AUTOMATIC FUNCTIONING .....	22
SELECTION OF THE MAXIMUM DURATION AND TYPE OF MUTING .....	23
OVERRIDE CONFIGURATION .....	23
MUTING OVERRIDE FUNCTION (“LP4ER_M” MODELS) .....	24
"SYSTEM STATUS" OUTPUT (“M” MODELS) .....	25
TEST FUNCTION.....	25
SAFETY MODULES MJB1 - MJB2 - MJB3 - MJB4 .....	25
EXAMPLE OF CONNECTION WITH EXTERNAL CONTACTORS K1/K2 WITH start/restart interlock activated .....	26
EXAMPLE OF CONNECTION WITH AD SB300 WITH start/restart interlock activated .....	27
MUTING STATUS AND LIGHT (“LP4ER_M” MODELS) .....	27
<b>CONFIGURATION AND OPERATION MODES LP4ER_L12 .....</b>	<b>28</b>
AUTOMATICO MODE.....	28
MANUAL MODE .....	29
<b>DIMENSIONS .....</b>	<b>30</b>
<b>LP4ER_M &amp; LP4ER_L.....</b>	<b>30</b>
<b>TECHNICAL DATA .....</b>	<b>31</b>
<b>CHECKS AND MAINTENANCE .....</b>	<b>34</b>
<b>TROUBLESHOOTING .....</b>	<b>35</b>
<b>ACCESSORIES .....</b>	<b>37</b>
<b>COMPLIANCE .....</b>	<b>38</b>
<b>GUARANTEE .....</b>	<b>38</b>

## Original Instructions (ref. 2006/42/EC)

### INTRODUCTION

---

---

 This symbol indicates an important personal safety warning. Failure to comply with the warning may result in very high risks for exposed personnel.

The LP4 safety light curtain is a multi-beam opto-electronic safety system of the Type 4 category of electro-sensitive devices (in accordance with IEC 61496-1; EN 61496-2 and complies with the requirement of the EU Machinery Directive 2006/42/EC) - if necessary equipped with MUTING function ("M" models) - for the protection of persons exposed to dangerous machines or plants.

The two PNP auto-controlled static outputs permit connection of the light curtain to a control system complying with the requirements and level of safety required for the application.

The light curtain integrates the start/restart interlock and EDM functions (control of external relays K1 and K2). In this way, the light curtain can be connected to a simple pair of relays or external safety contactors without having to install additional modules.

A diagnostic display on the Emitter and Receiver provides the information required for correct use of the device and to check for any operating faults.

The diagnostic output (see TROUBLESHOOTING, page 35) makes it possible to obtain weak signal and light curtain status information from a single wire.

LP4 is ideal for protecting:

- automatic palletizing/depalletizing systems
- materials handling and storage systems;
- packing and packaging machines;
- assembly lines;
- industrial automatic warehouses;
- AGV transit openings;
- metal, wood, marble and glass tool machines;
- presses, die cutting machines.

 For problems regarding safety, if necessary, consult the competent safety authorities of your country or the related industrial association.

 For applications in the food industry, consult the manufacturer to check compatibility between the materials of the light curtain and the chemical agents used.

 The guarding function of opto-electronic safety devices is not effective in the case in which the machine cannot be electrically controlled and is unable to stop the dangerous movement immediately at any time during the work cycle.

## PRINCIPLE OF OPERATION

### LIGHT CURTAIN

If the area guarded is clear, the two outputs on the Receiver are active and permit normal functioning of the machine connected to these.

When an object larger than or equal to the resolution of the system interrupts the sensing field of one or more beams, the Receiver de-activates its outputs.

This condition makes it possible to block the dangerous movement of the machine (using a suitable machine stop circuit).

Resolution is the smallest diameter object that will be reliably detected by at least one of the optical beams generated by the light curtain (Figure 1).

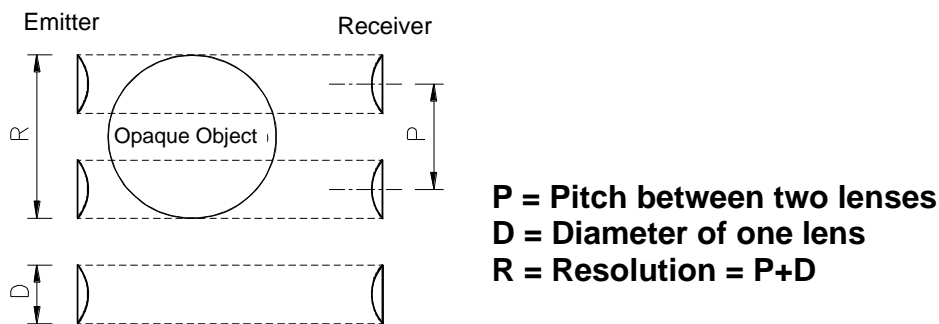

Figure 1- Light curtain resolution

Resolution is constant regardless of working conditions as it depends only on the geometrical characteristics of the lenses and the center distance between two adjacent lenses. The height of the guarded area is the height effectively protected by the safety light curtain.

If the curtain is positioned horizontally, this value indicates the depth of the guarded zone. The useful range is the maximum operating distance that can exist between the Emitter and Receiver.

LP4 is available with the following resolutions (MODEL "LP4ER\_M") :

- 30mm (protected heights from 300mm to 1200mm) ("LP4ER\_M" models):  
**PROTECTION OF THE HANDS.**
- 40mm (protected heights from 300mm to 1800mm) ("LP4ER\_M" and LP4ER\_L models):  
**PROTECTION OF THE HANDS.**
- 90mm (protected heights from 300mm to 1800mm) ("LP4ER\_M" models):  
**PROTECTION OF THE LIMBS.**

LP4 is also available in a **Multibeam** version (LP4ER, LP4ER\_M, LP4ER\_L and LP4ER\_ML) with a pitch between the lenses of:

- 500mm (2 beams), 400mm (3 beams), 300mm (4 beams only models "LP4ER\_M").  
**PROTECTION OF THE BODY.**

## MUTING FUNCTION

 The Muting function is a temporary suspension of the safety light curtain's protective function. Carefully check your risk analysis in order to assess whether the Muting function is compatible with your application and what additional measures have to be taken.

The Muting function generates a **temporary, automatic interruption of safety light curtain functioning** in order to permit normal transit of material through the guarded opening.

The Muting function is activated when the system detects the object that interrupts the opening protected. In other words, when the system recognizes the material and distinguishes between this and any operator (in a potentially dangerous situation), it is enabled to bypass the light curtain temporarily, allowing the material to pass through the opening.

The Muting sensors external (**model "LP4ER\_M"**) form the sensing system that decides whether the Muting function is to be activated (or not). Control of the dangerous opening can be de-activated only by a correct sequence of interruption of the beams of the Muting sensors.

The LP4 system is available in models to which 2 or 4 sensors of various type can be connected (proximity, optical, capacitive etc).

### **LP4ER\_M MODEL– external sensors** **3 selectable methods of Muting.**

The "LP4ER\_M" model can use 2 or 4 sensors that must be connected to the M12 connectors on the front part of the vertical light curtain. These sensors may be of various types (proximity, optical, capacitive with PNP or electromechanical type output and with DARK-ON switching (i.e. output active when material is present).

If 4 sensors are connected, it is possible to choose two methods of operation: 1) **Concurrent**; 2) **Sequential**.

#### **CONNECTION WITH 2 EXTERNAL SENSORS (Figure 2)**

This model is two-way and is useful for protecting pallet entrance/exit openings.

 The point of intersection of the two sensors must be located inside the dangerous area to prevent accidental and dangerous activation of the Muting function.

The Muting function is activated following concurrent interruption (within max. 4s) of sensors S1 and S2. The Muting function continues as long as both sensors are occupied. When the first of the two sensors is cleared, the Muting function is disabled.

Also for this model, the maximum duration of the Muting condition (timeout) can be set to 30 seconds or 90 minutes.

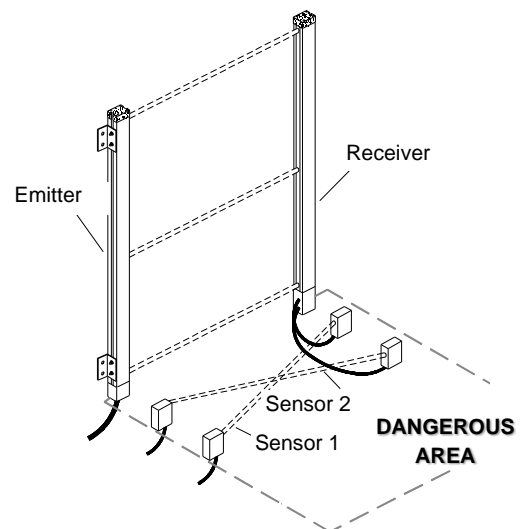

Figure 2

**CONNECTION WITH 4 EXTERNAL SENSORS**

Using 4 sensors, two methods of operation are possible:

**Sequential (figure 7)**

The Muting function is activated following sequential interruption of sensors S1 and S2 and of sensors S3 and S4. **It is important to remember that, for correct actuation of the Muting function, the sequence indicated in Figure 4 and Table 1 is required (without time restrictions).**

It is also possible to enable a control of the activation time of the 4 sensors.

**Concurrent**

The Muting function is activated following concurrent interruption of sensors S1 and S2 (within maximum 4sec) (or S4 and S3 with material transiting in the opposite direction). **Muting status ends after clearing of the opening and of S3 (or S2 with material transiting in the opposite direction).**

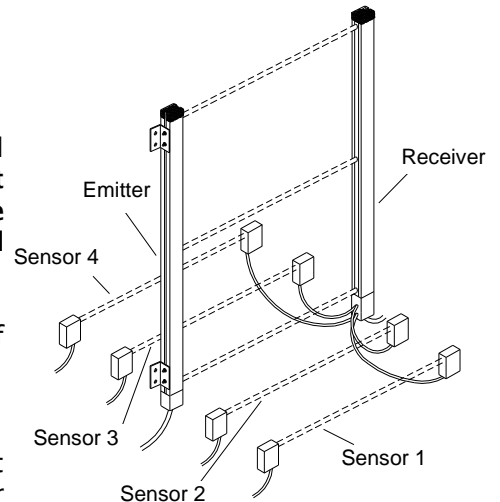

Figure 3

➔ The LP4ER\_M models connected with 4 external sensors, have two available timeouts: 1) 30 sec; 2) infinite.

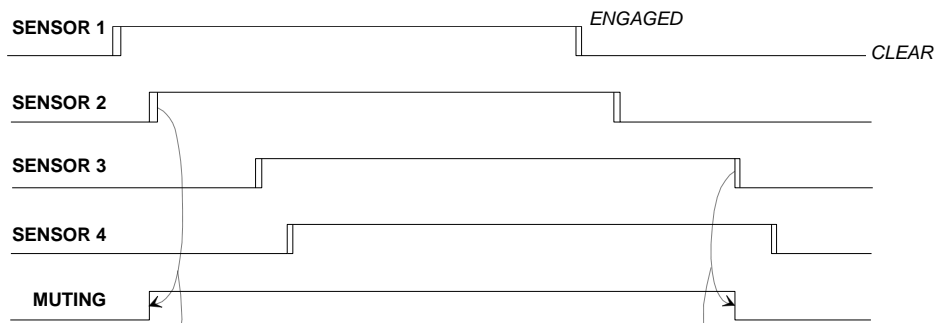

Figure 4

Sequential muting: activation sequence.

SENSOR 1	SENSOR 2	SENSOR 3	SENSOR 4	LIGHT CURTAIN STATUS
0	0	0	0	LIGHT CURTAIN ACTIVE
1	0	0	0	LIGHT CURTAIN ACTIVE
1	1	0	0	MUTING
1	1	1	0	MUTING
1	1	1	1	MUTING
0	1	1	1	MUTING
0	0	1	1	MUTING
0	0	0	1	LIGHT CURTAIN ACTIVE
0	0	0	0	LIGHT CURTAIN ACTIVE

Table 1

**LEGEND:**

**0 = SENSOR FREE; 1 = SENSOR ENGAGED**

Both operating modes with 4 sensors are TWO-WAY.

The correct Muting sequence can start either from sensor 1 or from sensor 4.

## LP4ER\_M MODELS USED WITH "L" OPERATIONAL LOGIC

In this model the sensors 1 and 2 are on the same side with respect to the vertical curtain and are positioned in front of the dangerous opening (Figure 5 and Figure 6). This model is unidirectional and is useful for protecting openings with pallet exit.

The activation of the Muting function takes place following the simultaneous interruption (within max. 4 sec) of sensors S1 and S2. The Muting function remains while both sensors are occupied. On release of the first of the 2 sensors, the material will still have 4 seconds available to abandon the protected area delimited by the curtain. The Muting condition will be disabled as soon as the protected area is released.

If the curtain is still occupied after the 4 seconds, the OSSD outputs are disabled, interrupting machine functioning.

For this model, the maximum duration of the Muting condition (timeout) can be selected in 30 seconds or 90 minutes (Table 12).



It is indispensable that a Muting sequence is completed (release of controlled area) in order to guarantee the correct activation of the successive sequence.



For safe functioning of the MI series (with L logic), it is necessary that the muting sensors are positioned inside the dangerous area (traced in Figure 5 and Figure 6).

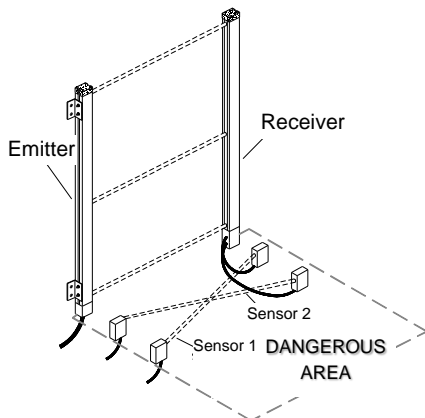

Figure 5 - Crossed sensors

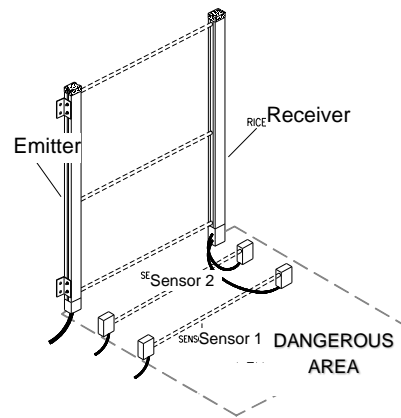

Figure 6 - Parallel sensors

## INSTALLATION

Before installing the LP4 safety system, check that:

- The safety system is used only as stopping device and not as machine control device.
- The machine can be controlled electrically.
- Any dangerous action of the machine can be promptly interrupted. In particular, the stopping time of the machine must be known, if necessary measure this.
- The machine must not cause dangerous situations due to flying or dropping of material; otherwise, additional mechanical guards are required.
- The minimum size of the object that must be detected must be greater than or equal to the resolution of the model selected.**

Knowing the shape and dimensions of the dangerous area, it is possible to assess the width and height of its access area:

**☛ Compare these dimensions with the maximum useful range and the height of the area protected of the model used.**

Before positioning the safety device, take into account the following general indications:

- ☛ Check that the temperature of the environments where the system is installed is compatible with the temperature operating parameters indicated in the technical data.**
- ☛ Do not position the Emitter and Receiver close to sources of bright light or high intensity flashing lights.**
- ☛ Particular environmental conditions may impair the detection efficiency of light curtains. In places with the possibility of mist, rain, fumes or dust, for correct functioning of the equipment it is advisable to apply suitable correction factors  $F_c$  to the values of useful operating range. In these cases:**

$$P_u = P_m \times F_c$$

where  $P_u$  and  $P_m$  are respectively the useful and maximum operating range in meters.

The recommended  $F_c$  factors are indicated in the table below.

ENVIRONMENTAL CONDITION	CORRECTION FACTOR $F_c$
Mist	0,25
Vapors	0,50
Dust	0,50
Dense fumes	0,25

Table 2

- ☛ If the device is installed in areas liable to sudden changes in temperature, suitable measures must be taken in order to avoid formation of condensation on the lenses, which could impair detection efficiency.**
- ☛ If LP4 light curtains are used with palletizers, depalletizers and stacking/destacking machines for empty pallets, refer to European standard EN 415-4.**

## POSITIONING

Protection of the guarded opening by LP4 must be integrated with suitable mechanical guards.

### POSITIONING OF THE MUTING SENSORS ("LP4ER\_M" SERIES).

#### 2 sensors

The Emitter and receiver of the light curtain must be positioned so as to permit access to the dangerous area from above, from below and from the sides without first of all intercepting at least one of the optical beams.

Indications for correct positioning of the light curtain are provided in the figure below.

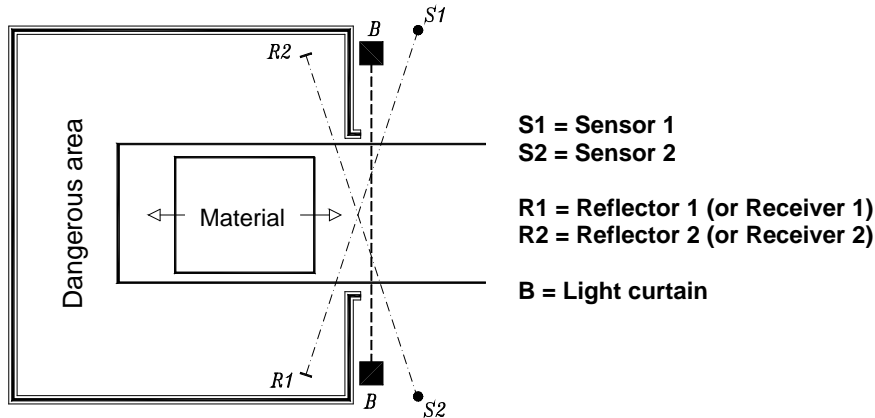

Figure 7

For correct positioning of sensors 1 and 2, i.e. those that manage enabling and disabling of the Muting function, take into account the following:

- the two beams must be crossed and pass diagonally through the zone guarded by the light curtain;
- the point of intersection of the two beams must be **in the dangerous area beyond the light curtain**;
- the angle between the two Muting beams must be calculated according to the size of the pallet and its speed, taking into account that the Muting function is activated only if the interception delay between the two sensors is less than 4 seconds;
- the pallet must interrupt the two beams **before** intercepting the light curtain;
- the two beams must be interrupted continuously by the pallet for the entire period during which the pallet passes between the sensors;
- make sure that the two beams are effectively intercepted by the material on the pallet and not by the empty pallet;
- the zone identified by the points of interception and clearing of the beams of sensors 1 and 2 by pallet **must be limited as far as possible (or suitably protected)** so as to avoid the possibility of accidental passing through the light curtain with Muting active (Figure 8).



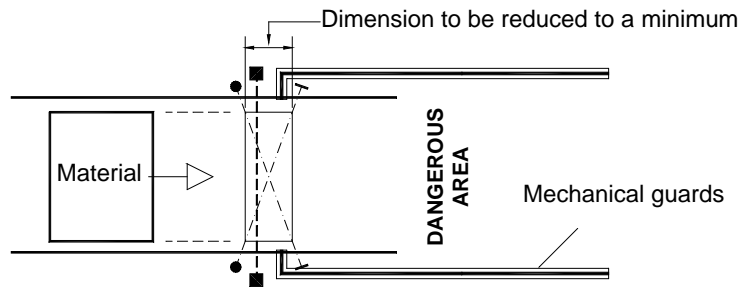

Figure 8

#### 4 sensors

For correct positioning of sensors 1, 2, 3 and 4, i.e. those that manage enabling and disabling of the Muting function, take into account the following:

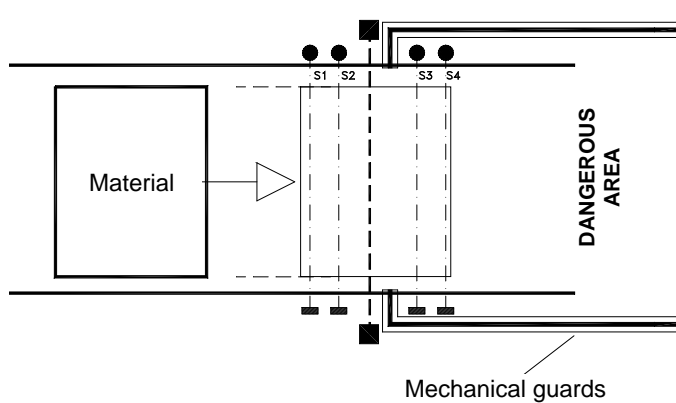

Figure 9

#### SEQUENTIAL (Figure 4, Figure 9 Table 1):

- the distance between the first and the last sensor must never exceed the length of the pallet (**in one of the phases of the sequence, the 4 sensors must all be intercepted simultaneously**);
- the pallet must interrupt sensors S1 and S2 (or S4 and S3 in the opposite direction) **before** intercepting the light curtain;
- make sure that the two beams are intercepted by the material on the pallet and not by the empty pallet

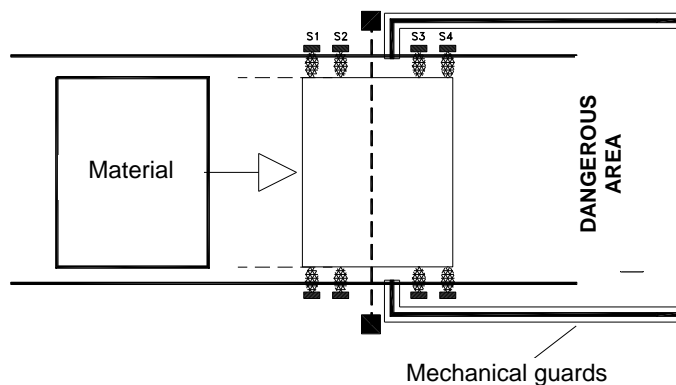

Figure 10

#### CONCURRENT (Figure 10):

- The Muting function is activated following concurrent interruption (**within max. 4 sec**) of sensors S1 and S2 (or S4 and S3 in the opposite direction).
- also in this operating mode, for correct activation of the Muting function, **for a short period of time, all 4 sensors must be intercepted simultaneously.**

**CALCULATION OF THE SAFETY DISTANCE**

The light curtain must be positioned at a distance exceeding or equal to the **minimum safety distance S** so that a dangerous point can be reached only after stopping the dangerous action of the machine (Figure 11).

Referring to European standard EN999, the minimum safety distance **S** must be calculated according to the following formula:

$$S = K(t_1 + t_2) + C$$

where:

<b>S</b>	minimum safety distance	mm
<b>K</b>	speed of approach of the body to the danger area.	mm/sec
<b>t<sub>1</sub></b>	total response time in seconds of the safety light curtain	sec
<b>t<sub>2</sub></b>	response time of the machine in seconds, i.e. the time taken by the machine to interrupt the dangerous action from the moment in which the stop signal is transmitted	sec
<b>C</b>	additional distance	mm

- ❗ Failure to comply with the safety distance reduces or defeats the protective function of the light curtain.
- ❗ If the position of the light curtain does not exclude the possibility of the operator accessing the danger area without being detected, the system must be equipped with additional mechanical guards.

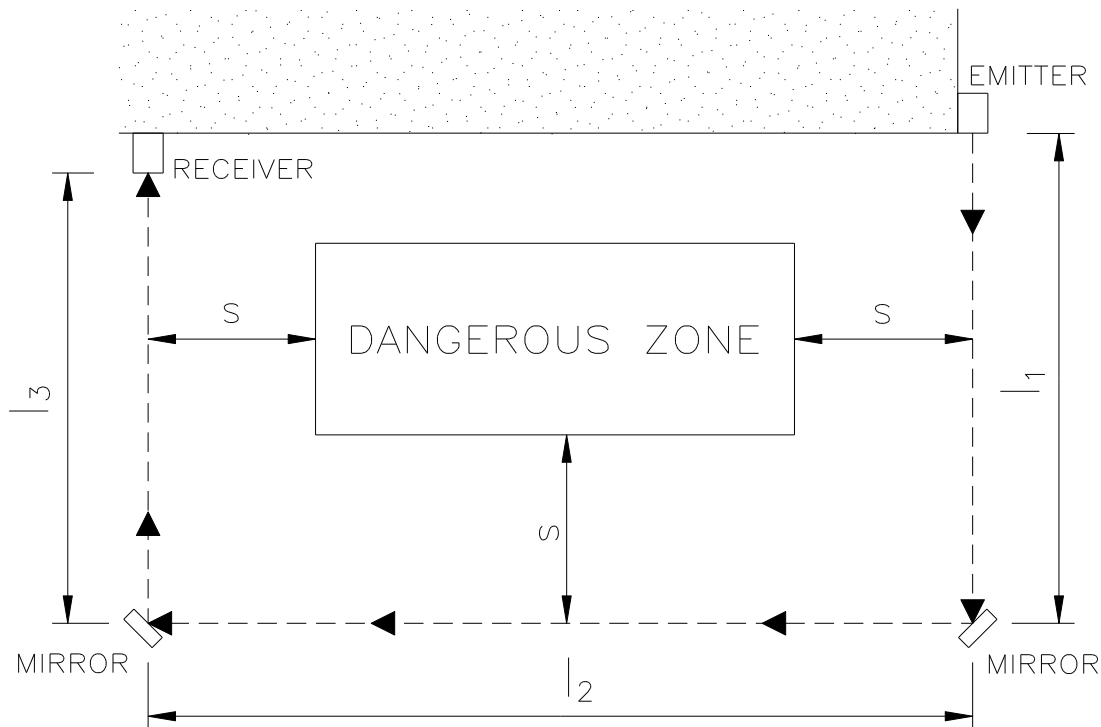

Figure 11

**VERTICAL POSITIONING OF THE LIGHT CURTAIN**



Models with resolution 30, 40mm.

These models are suitable for detecting the hands

The minimum safety distance  $S$  is calculated according to the following formula:

$$S = 2000 (t_1 + t_2) + 8(D-14)$$

(D=resolution)

This formula is valid for distances  $S$  between 100 and 500 mm. If, according to the calculation,  $S$  exceeds 500 mm, the distance can be reduced up to a minimum of 500 mm using the following formula:

$$S = 1600 (t_1 + t_2) + 8 (D-14)$$

Where, due to the particular configuration of the machine, it is possible to access the danger area from above, the highest beam of the light curtain must be at a height  $H$  of at least 1800 mm from the resting surface  $G$  of the machine.

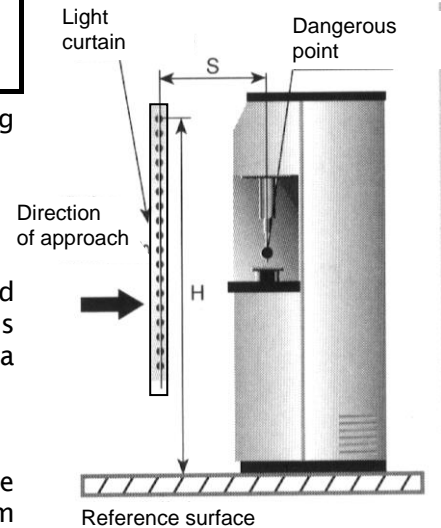

Figure 12



Models with resolution 90mm.

These models are suitable for detecting the arm or legs and must not be used to detect the fingers or hands.

The minimum safety distance  $S$  is calculated according to the following formula:

$$S = 1600 (t_1 + t_2) + 850$$

In any case, the height  $H$  of the highest beam from the reference surface  $G$  must not be less than 900 mm while the height of the lowest beam  $P$  must not exceed 300 mm.

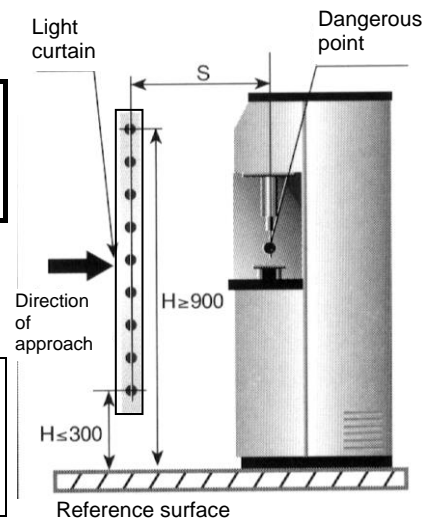

Figure 13



**Multibeam Models**

**These models are suitable only for detection of the entire body.**

The minimum safety distance **S** is calculated according to the following formula:

$$S = 1600 (t_1 + t_2) + 850$$

**→ The recommended height H from the reference surface G (ground) is as follows:**

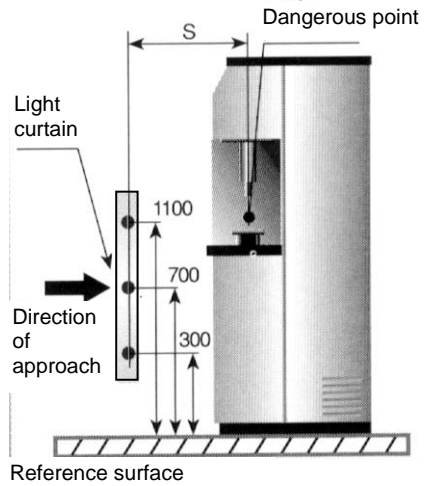

Figure 14

MODEL	BEAMS	Recommended height H (mm)
2B	2	400 – 900
3B	3	300 – 700 – 1100
4B	4	300 – 600 – 900 - 1200

**For applications on packaging machines (palletizers and depalletizers), comply with the indications of European standard EN 415-4, which are repeated below.**

Dimensions in m

Type of access

**From low level (floor)  
 Device with minimum 3 beams**

**Above the conveyor (roller bed)  
 Device with minimum 2 beams**

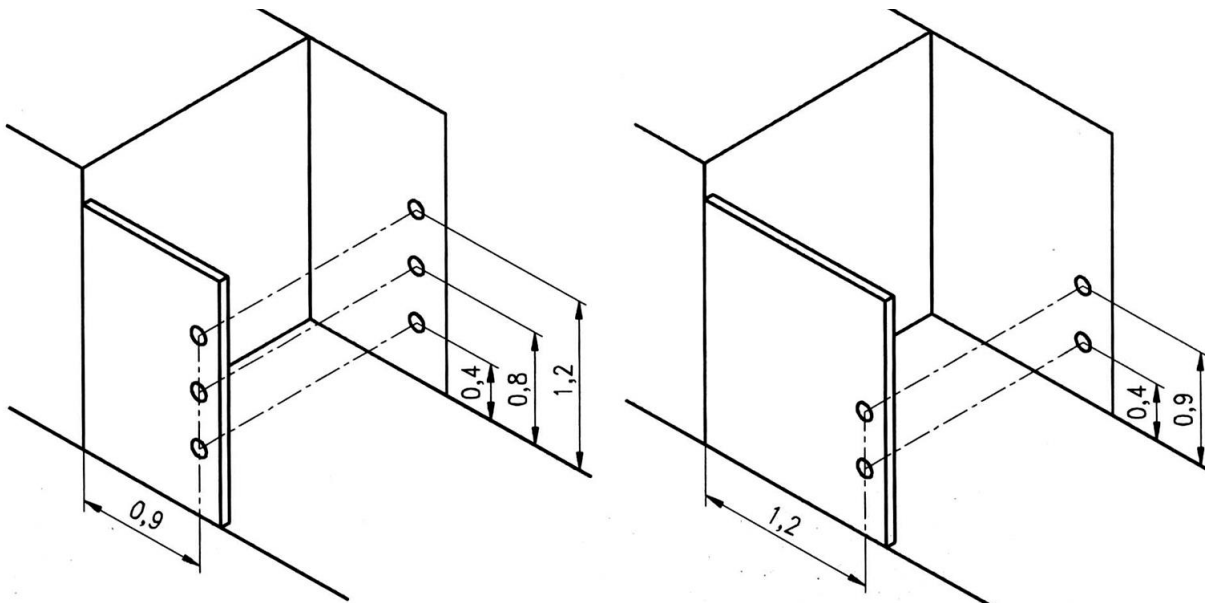

Figure 15

Protection of the opening with LP4 light curtain and mechanical side guards.

**MULTIPLE SYSTEMS**

When several LP4 systems are used, these must not interfere optically with each other. Position the elements so that the beam emitted by the Emitter of a system is received only by the respective Receiver.

Figure 16 provides various examples of correct positioning of two photo-electric systems. Incorrect positioning could generate interference and possibly result in irregular functioning.

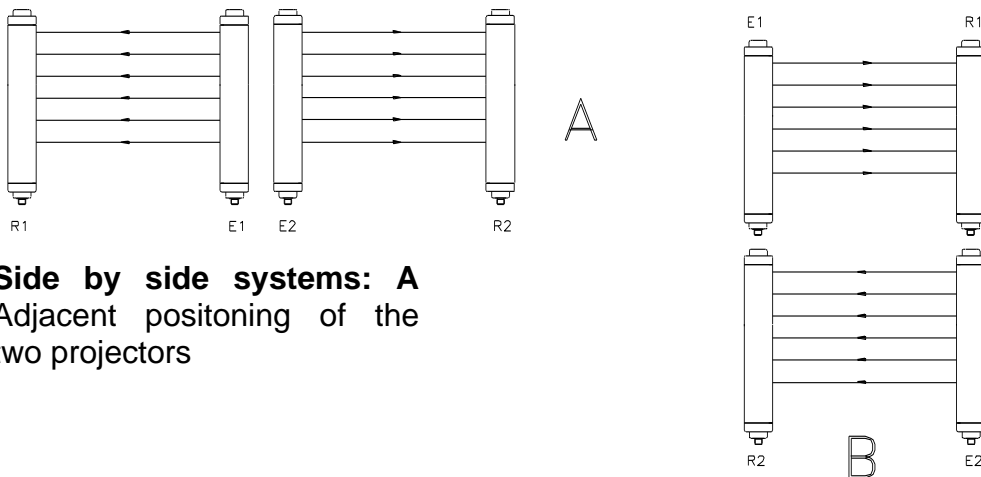

Figure 16

**DISTANCE FROM REFLECTIVE SURFACES**

The presence of reflective surfaces close to the light curtain may cause spurious reflections that prevent detection. Referring to Figure 17, object **A** is not detected because of surface **S** which, reflecting the beam, closes the sensing field between the Emitter and Receiver. A minimum distance **d** must therefore be maintained between any reflective surfaces and the protected area. The minimum distance **d** must be calculated according to the distance **l** between Emitter and Receiver and taking into account that the angle of projection and reception is equal to 4°.

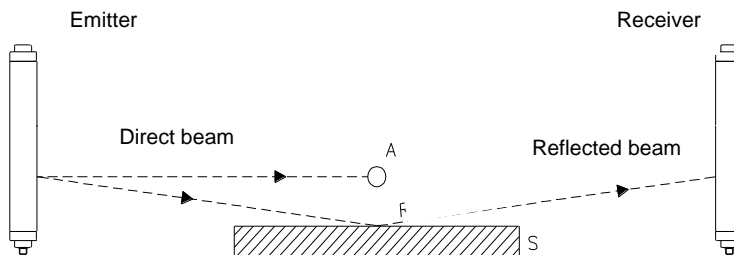
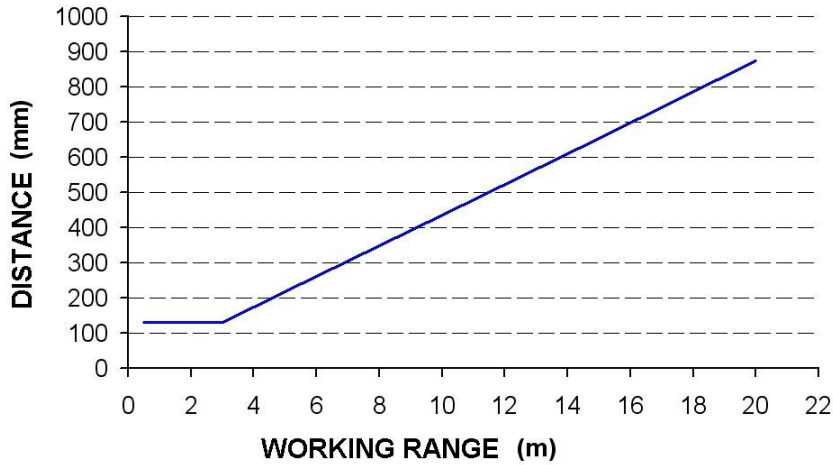

Figure 17

Figure 18 indicates the values of the minimum distance **d** to be complied with as the distance **l** between Emitter and Receiver varies.

**Additional measures may be necessary to ensure that the ESPE does not fail to danger when other forms of light radiation are present in particular applications (for example use of cableless control devices on cranes, radiation from weld splatter or effects from stroboscopic lights).**

**LP4**



**LP4 Long Range**

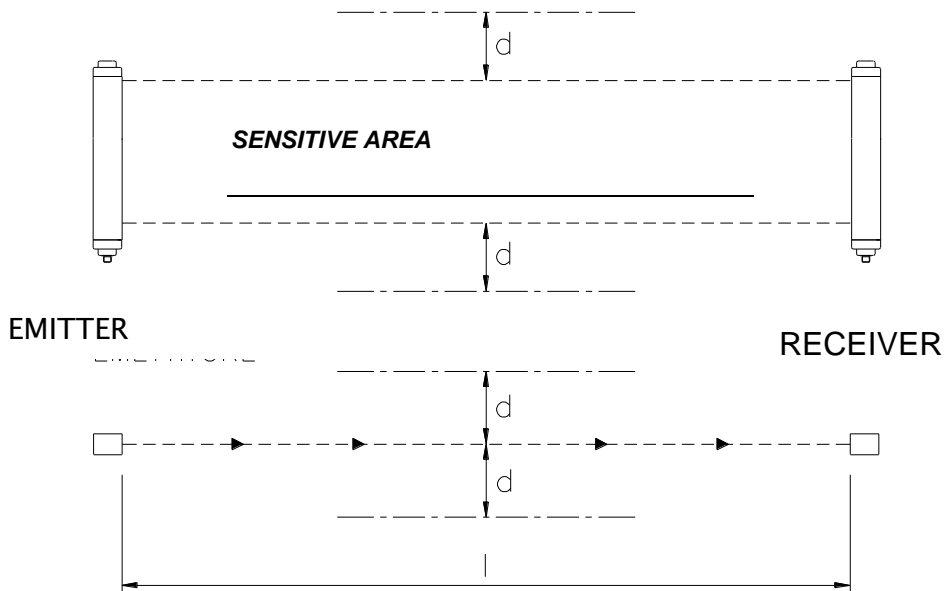
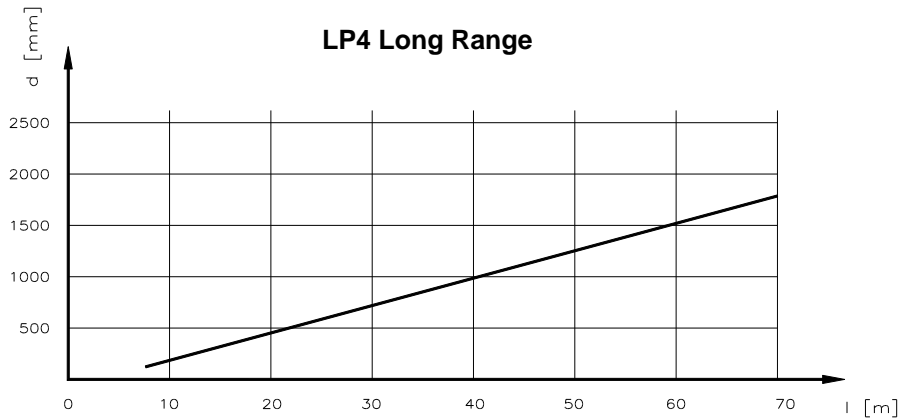

Figure 18

After installation, check for any reflective surfaces, intercepting the beams first of all at the center and those close to the Emitter and Receiver.

During this procedure, the red led on the Receiver must never switch off.

**LIGHT SIGNALS**

**EMITTER SIGNALS**

At power-on, all the leds are ON for a period of 5 seconds.  
 Subsequently, the leds display functioning condition.

**"LP4ER" MODELS**

**"LP4ER\_M" MODELS**



Figure 19



LED	MEANING NORMAL FUNCTIONING (LED ON)	COLOR
Test 	Light curtain under test	YELLOW
	Light curtain functioning	GREEN
	Fault detected	RED
<b>RANGE</b>	High range selected *	ORANGE

Table 3

If a fault is detected, the led will indicate the type of alarm (ref. "TROUBLESHOOTING").

\* The value of the selected range depends on the LP4 model. (Refer to TECHNICAL DATA - page 31).

**RECEIVER SIGNALS**

At power-on, for a period of 5 seconds, the display will show the number "8" and all the leds will be ON. In the next 10 seconds, the display and the leds will show the configuration selected. At initial power-on after installation, always check the accuracy of these settings very carefully.

This check is also indispensable in all cases of malfunctioning (ref. "TROUBLESHOOTING").

During display of the configuration, the display will show the letter "C" while during normal functioning, a hyphen "-" will be displayed.

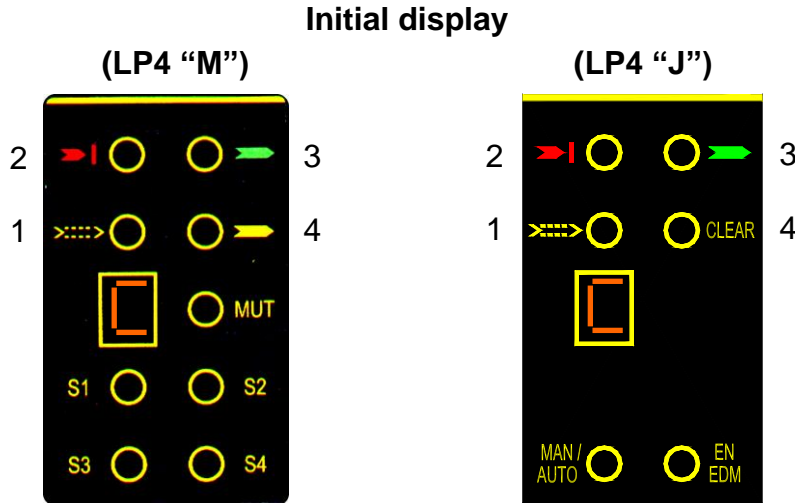

Figure 20

	LED	INITIAL CONFIGURATION		COLOR	
		(LED ON)	(LED OFF)		
LP4ER_M	S1	Enabling of timeout 30s	Enabling of timeout 90min	YELLOW	
	S2	With 4 sensors, enabling of Sequential muting	With 4 sensors, enabling of concurrent op. mode	YELLOW	
	S3	Manual functioning mode enabled	Automatic functioning mode enabled	YELLOW	
	S4	Control of feedback external relays enabled	Control of feedback external relays disabled	YELLOW	
	MUT	Muting configuration with 4 sensors	Muting configuration with 2 sensors	YELLOW	
	Weak (1)	>:--->	-	-	ORANGE
	Break (2)	>	OSSD outputs set to OFF	-	RED
	Guard (3)	>---	-	-	GREEN
	Clear/Override (4)	>---	Push button override	Spring return key override	YELLOW

LP4ER	Weak (1)	>:--->	-	-	ORANGE
	Break (2)	>	OSSD outputs set to OFF	-	RED
	Guard (3)	>---	-	-	GREEN
	Clear (4)	CLEAR	-	-	YELLOW
	MAN/AUTO		Manual functioning mode enabled	Automatic functioning mode enabled	YELLOW
	EN EDM		Control of feedback external relays enabled	Control of feedback external relays disabled	YELLOW

Table 4



**Normal display**

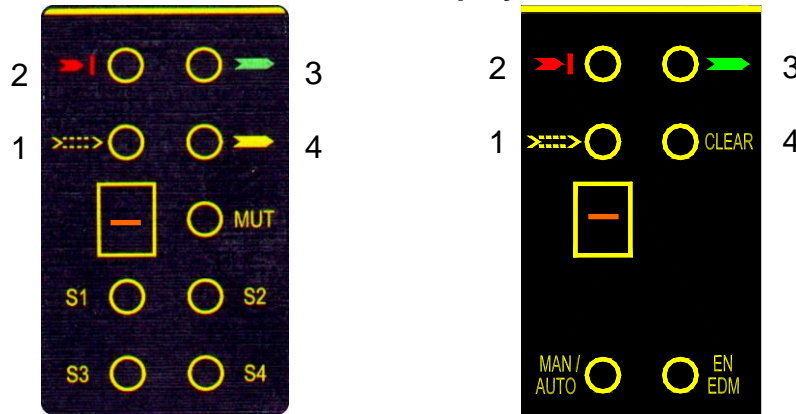

Figure 21

	LED	NORMAL FUNCTIONING		COLOR	
		(LED ON)	(LED OFF)		
LP4ER_M	S1	Interruption Sensor 1	Sensor 1 clear	YELLOW	
	S2	Interruption Sensor 2	Sensor 2 clear	YELLOW	
	S3	Interruption Sensor 3	Sensor 3 clear	YELLOW	
	S4	Interruption Sensor 4	Sensor 4 clear	YELLOW	
	MUT	Muting active *	Light curtain active	YELLOW	
	Weak (1)		Weak signal received	Signal received OK	ORANGE
	Break (2)		Light curtain occupied, OSSD outputs set OFF	-	RED
	Guard (3)		Light curtain clear, OSSD outputs set ON	-	GREEN
	Override_1 (3)		Light curtain in override, OSSD outputs set ON **	-	
	Clear (4)		Light curtain clear, OSSD outputs set OFF (the receiver is waiting for a Restart signal)	-	YELLOW
Override_2 (4)		Override request (BLINKING LED)	-		

\* The Muting/Override lamp lights on.

\*\* A small "o" letter appears on the display and at the same time the external Muting/Override lamp blinks.

LP4ER	Weak (1)		Weak signal received	Signal received OK	ORANGE
	Break (2)		Light curtain occupied, OSSD outputs set OFF	-	RED
	Guard (3)		Light curtain clear, OSSD outputs set ON	-	GREEN
	Clear (4)	CLEAR	Light curtain clear, OSSD outputs set OFF (the receiver is waiting for a Restart signal)	-	YELLOW



Table 5

In case of fault, only the red led will remain ON and the display will show a flashing "C" or "F" followed by the fault code (ref. TROUBLESHOOTING paragraph).

## ELECTRICAL CONNECTIONS AND CONNECTORS

### Caution

Before making the electrical connections, always check that the voltage available matches that indicated in the technical data.

-  **The Emitter and Receiver must be powered at 24Vdc±20%.**
-  **The external power supply must be of type SELV and comply with standard EN 60204.**

The electrical connections must be made according to the diagrams provided in this manual.

In particular, never connect other devices to the connectors of the Emitter and Receiver.

To assure dependable functioning, if an alternate current source (e.g. transformer) is used, it must provide adequate power, have a double insulation and, using a diode bridge rectifier and capacitor downstream, supply a voltage not exceeding 28.8V, the output capacity must be at least 2000uF for each Ampere absorbed.

### EMITTER CONNECTIONS (MALE CONNECTOR)

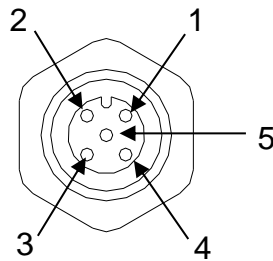

MOD	PIN	COLOR	NAME	TYPE	DESCRIPTION	FUNCTIONING
LP4ER, LP4ER_L, LP4ER_M	1	Brown	24VDC	IN	24Vdc power supply	Protected with 2A fuse
	2	White	SEL RANGE/TEST1	IN	INPUT1 for range/test selection	see table "RANGE and TEST SELECTION"
	3	Blue	0VDC	IN	0Vdc power supply	-
	4	Black	SEL RANGE/TEST2	IN	INPUT2 for range/test selection	see table "RANGE and TEST SELECTION"
	5	Grey	PE	-	Ground connection	-

RANGE and TEST SELECTION LP4ER, LP4ER_L, LP4ER_M models)		
PIN 2	PIN 4	MEANING
+24 Vdc	0 Vdc *	LOW range (Refer TECHNICAL DATA - page 31)
0 Vdc *	+24 Vdc	HIGH range (Refer TECHNICAL DATA - page 31)
0 Vdc *	0 Vdc *	EMITTER IN TEST CONDITION
+24 Vdc	+24 Vdc	Condition not allowed
* (0 Vdc or open circuit)		

Table 6

**RECEIVER CONNECTIONS (MAIN CONNECTOR - MALE)**

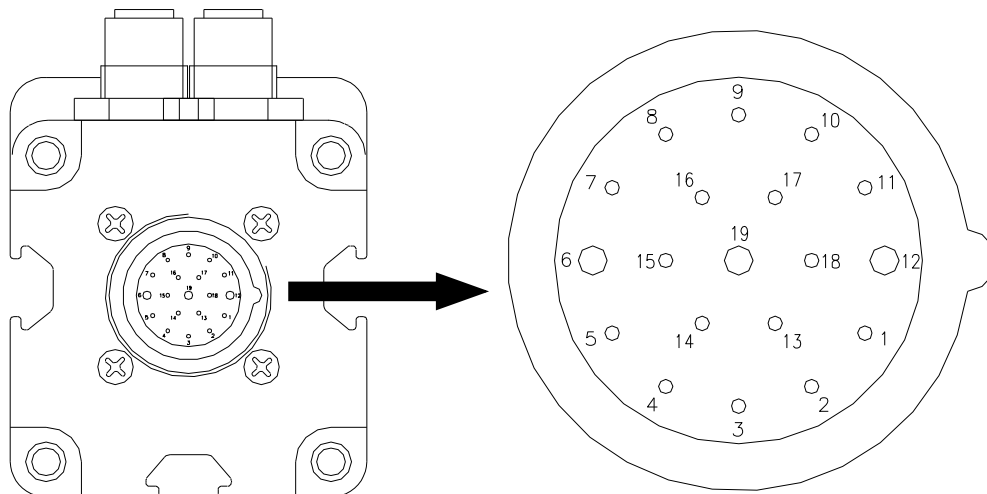

➔ Make sure the M23 connector is screwed down tightly to ensure correct barrier operation! (4 turns)

PIN	COLOR	NAME	TYPE	DESCRIPTION	FUNCTIONING
* 1	White	MUT. LAMP	OUT	Muting lamp output	with Muting active
2	Red	OSSD2	OUT	Safety outputs	with : <ul style="list-style-type: none"> <li>• Light curtain clear</li> <li>• Muting active</li> <li>• Muting Override</li> </ul>
3	Grey	OSSD1	OUT		
4	Yellow	STATUS	OUT	Weak signal condition + OSSD status	ref. Figure 23
5	Green	N.C.	-	-	-
6	Blue	0VDC		0Vdc power supply	-
* 7	Violet	CONF0	IN	Configuration of Muting characteristics	ref. Table 12
* 8	Pink	CONF1	IN		
* 9	Grey-Pink	CONF2	IN		
* 10	Red-Blue	CONF3	IN		
11	White-Green	ENABLE_K	IN	Enabling of external contactor control	ref. Table 10
12	Black	PE		Ground connection	-
13	White-Yellow	MAN/AUTO	IN	Manual / Automatic mode selection	ref. Table 11
14	Yellow-Brown	RESTART	IN	Restart	Active on LO-HI transition (min. duration of the signal 400 msec)
15	White-Grey	N.C.			
* 16	Grey-Brown	OVERRIDE1	IN	Override signals	ref. Table 13
* 17	White-Pink	OVERRIDE2	IN		
18	Brown-Green	FEED_K1K2	IN	Feedback external contactors	ref. Table 10
19	Brown	24VDC		24Vdc power supply	

Table 7

\* Connection present only in "LP4ER\_M" models (with MUTING function)

**CONNECTOR M12 n.1 (FOR MUTING SENSOR) ("LP4ER\_M" MODELS) (FEMALE CONNECTOR)**

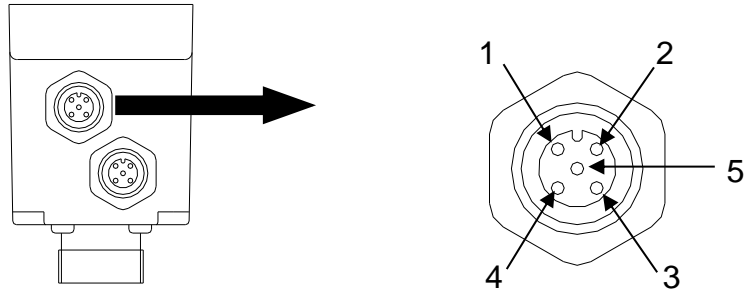

PIN	COLOR	NAME	TYPE	DESCRIPTION	FUNCTIONING
1	Brown	24 VDC	OUT	Power supply sensors 1 and 3	Positive
2	White	SENSOR 1	IN	Input SENSOR 1	< 5VDC : SENSOR FREE 11÷30 VDC : SENSOR ACTUATED
3	Blue	0 VDC	OUT	Power supply sensors 1 and 3	Negative
4	Black	SENSOR 3	IN	Input SENSOR 3	< 5VDC : SENSOR FREE 11÷30 VDC : SENSOR ACTUATED
5	Grey	PE	-	-	-

Table 8

**CONNECTOR M12 n.2 (FOR MUTING SENSOR) ("LP4ER\_M" MODELS) (FEMALE CONNECTOR)**

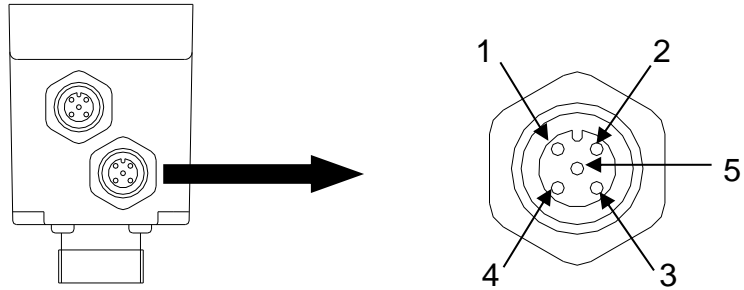

PIN	COLOR	NAME	TYPE	DESCRIPTION	FUNCTIONING
1	Brown	24 VDC	OUT	Power supply sensors 2 and 4	Positive
2	White	SENSOR 2	IN	Input SENSOR 2	< 5VDC : SENSOR FREE 11÷30 VDC : SENSOR ACTUATED
3	Blue	0 VDC	OUT	Power supply sensors 2 and 4	Negative
4	Black	SENSOR 4	IN	Input SENSOR 4	< 5VDC : SENSOR FREE 11÷30 VDC : SENSOR ACTUATED
5	Grey	PE	-	-	-

Table 9

**RECEIVER CONNECTIONS J LR M12 MODELS**

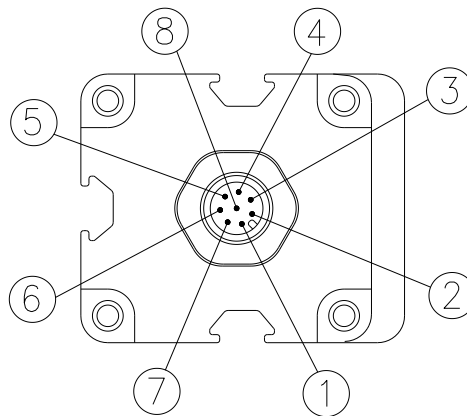

Figure 22

PIN	COLOR	NAME	TYPE	DESCRIPTION	OPERATION
2	Brown	24VDC	-	24VDC power supply	-
7	Blue	0VDC	-	0VDC	-
8	Red	PE	-	Ground connection	-
1	White	OSSD1	OUTPUT	Safety static outputs	PNP active high
3	Green	OSSD2	OUTPUT		
5	Grey	EXT_SEL_A	INPUT	Barrier configuration	According the normative EN61131-2
6	Pink	EXT_SEL_B	INPUT		
4	Yellow	EXT_K1_K2	INPUT	Feedback external contactors	

**SELECTION OF CONFIGURATION AND OPERATING MODE**

The inputs of the LP4 light curtain receiver make it possible to configure various operating modes. At power-on, for correct functioning, the various inputs must be connected as indicated below.

**SELECTION FEEDBACK EXTERNAL CONTACTORS K1/K2**

Feedback of the external contactors K1/K2 is enabled at system power-on (as indicated in Table 10). If this function is enabled, the set of N.C. contacts of the external relays must be connected to pin 18 of the receiver. The voltage level of this input must be:

- +24VDC with OSSD static outputs de-activated.
- 0VDC with OSSD static outputs activated.

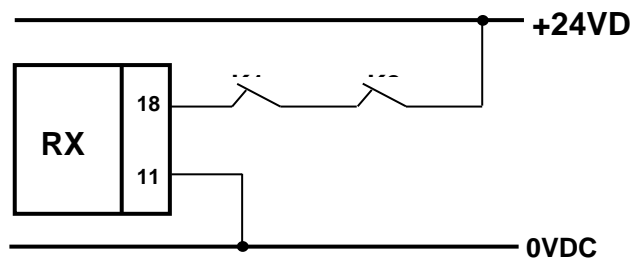

CONTROL OF EXTERNAL CONTACTORS K1/K2	Receiver pins		MEANING
	PIN 11	PIN 18	
	24VDC	0	Control disabled
	0		Control enabled
	0	0	Not permitted
	24VDC	24VDC	Not permitted

Table 10

**SELECTION OF MANUAL/AUTOMATIC FUNCTIONING**

Manual or automatic operating mode can be set through connection of pins 13 and 14 of the connector of the receiver.

- In AUTOMATIC functioning, the two static outputs OSSD1 and OSSD2 follow the status of the guarded opening. With the area guarded clear, the outputs will supply +24VDC, while with the area occupied they will supply 0VDC. Refer to Table 10 and Table 11 for correct configuration of operating mode.
- In MANUAL functioning, the two static outputs OSSD1 and OSSD2 are active only with the danger area clear and after the light curtain has received a correct RESTART signal. **This command must be sent on pin 14 of the receiver and is active with a 0VDC ---> +24VDC transition.**

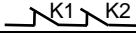
The minimum duration of the RESTART command must be 100ms.

 Use of manual mode (start/restart interlock activated) is compulsory if the safety device controls an opening to protect a danger area and a person, after passing through the opening, may remain in the danger area without being detected (use as 'trip device' according to IEC 61496). Failure to comply with this rule may result in very serious hazards for the persons exposed.

 The Restart control must be installed outside the danger area in a position where the danger area and the entire work area concerned are clearly visible. It must not be possible to reach the control from inside the danger area.

SELECTION OF MANUAL/AUTOMATIC FUNCTIONING		
CONNECTIONS		
AUTOMATIC		
MANUAL		
	<b>PIN 13</b>	<b>PIN 14</b>
NOT PERMITTED	0	0
	24VDC	24VDC

Table 11

**SELECTION OF THE MAXIMUM DURATION AND TYPE OF MUTING**

The inputs of the LP4 light curtain receiver make it possible to configure the various types of Muting available and the maximum duration of the Muting condition (timeout).

At power-on, for correct functioning, the various inputs must be connected as indicated below.

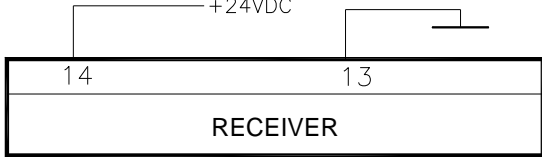
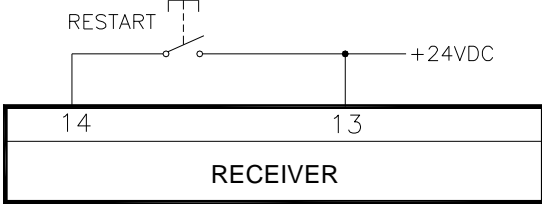
Model	Receiver pin				Timeout selected	MEANING
	10 (CONF3)	9 (CONF2)	8 (CONF1)	7 (CONF0)		
LP4ER_M (4 sensors)	0	0	0	24VDC	t1	Concurrent mode (within 4sec)
	0	0	24VDC	0	infinite	

Table 12 - Models LP4ER\_M with 4 sensors

where: t1 = 30 sec; t2 = 90 min

**OVERRIDE CONFIGURATION**



Receiver pin		MEANING
16 (OVERRIDE1)	17 (OVERRIDE2)	
0	0	Selection override with spring return key
0	24VDC	Selection override with push button (switch)
24VDC	0	Not permitted
24VDC	24VDC	Not permitted

Table 13

## MUTING OVERRIDE FUNCTION ("LP4ER\_M" MODELS)

The OVERRIDE function must be used when the machine stops due to incorrect Muting activation sequences with the material obstructing the guarded opening.

In this situation, the OSSD outputs are not active as the light curtain and/or at least one Muting sensor is occupied. In this condition the OVERRIDE request led blinks (ref. Table 5).

-  **This function activates the OSSD outputs making it possible to remove the material that is obstructing the opening concerned; moreover the Muting lamp lights on.**
-  **Throughout the entire phase during which the OVERRIDE function is active, the OVERRIDE/MUTING light is ON. Check efficiency of this light periodically (during the Muting or Override phases).**
-  **Warning!! The Override with pulse command automatically activates the outputs of the light curtain until both the light curtain and the muting sensors are free of obstacles again. During this period, the light curtain is unable to protect access to the guarded opening. Therefore, all operations must be carried out under the strict supervision of expert personnel.**

The operator will use the Override mode previously selected (ref. Table 13).

1. Override with continuous action command
2. Override with pulse command

### Override with continuous action command

This function is activated driving pins 16 and 17 of the receiver **to +24VDC** at the same time (**maximum delay = 400ms**) using a 2-way key selector with spring return;

PIN 16	PIN 17	CONDITION
0	0	Normal operation
24VDC	24VDC	OVERRIDE request

The maximum override duration is 15 minutes; it can be stopped for two different causes.

- **When the selector is released or if the 15 minutes has been elapsed, override ends**, de-activating the OSSD outputs, turning off the muting lamp and showing normal condition on the display. A new override condition can be started, releasing and rearming the selector.
- **Once the opening has been cleared and the sensors are free again**, override ends and GUARD condition (light curtain in normal operation) is activated without necessity of further commands.

### Override with pulse command

This function is activated inverting (**maximum delay = 400ms**) the condition of pin 16 and 17 of the receiver using a push button (switch). During the override the 16 and 17 are not controlled.

PIN 16	PIN 17	CONDITION
0	24VDC	Normal operation
24VDC	0	OVERRIDE request

The override condition can last a maximum of **15 minutes** (repeatable).

The function can only be re-started by pressing the pushbutton again (**subject to the following conditions**) :

1. Maximum total OVERRIDE time (after *n* consecutive requests) = **60 min**
2. Maximum number of consecutive requests for OVERRIDE = **30**.

The override condition ends when the barrier and sensors are cleared (entrance clear) and the GUARD condition is re-enabled (barrier fully operational) without sending any further commands.

The timer (point 1) and counter (point 2) are reset when one of the following conditions occurs:

- A correct muting sequence.
- A system reset (switched off and then turned on).



**"SYSTEM STATUS" OUTPUT ("M" MODELS)**

A signal that makes it possible to detect 2 separate items of information is available on pin 4 of the receiver:

1. **Weak signal arriving from the Emitter;**
2. **Status of the OSSD outputs.**
  - The output signal will be set to one (24 Vdc) or zero (according to the status of the OSSD) if the weak signal condition is not present
  - The output signal will be at one (24 Vdc) or zero with impulses towards 0 V or towards 24 in weak signal conditions.
  - The conditions of the signal concerned are summarized in the figure below:

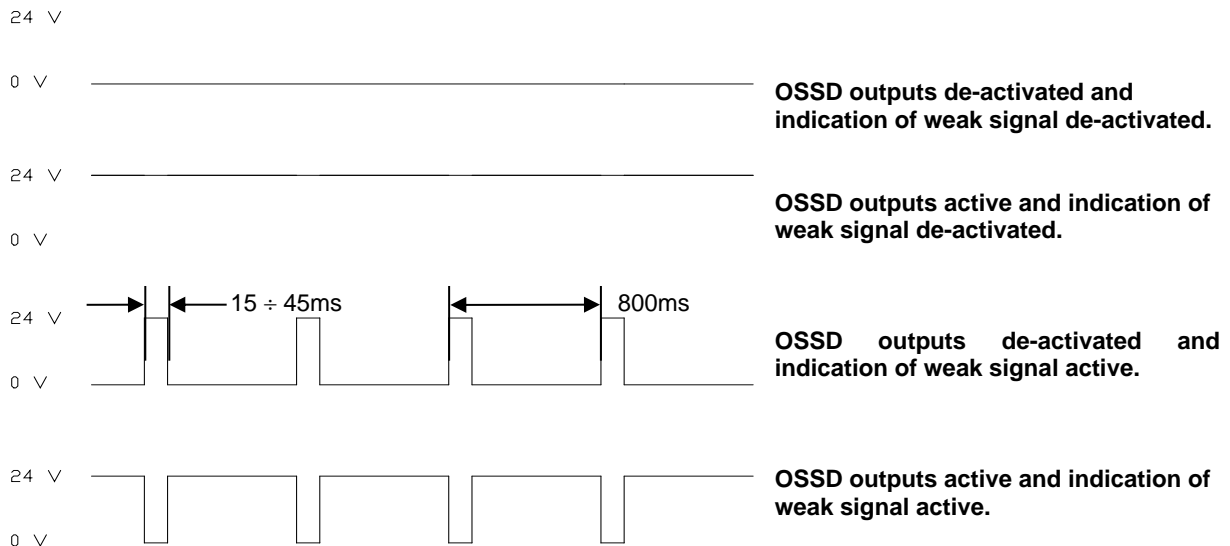

Figure 23

**TEST FUNCTION**

By means of the test function, which simulates occupation of the protected area, it possible to verify the operation of the entire system by means of an external supervisor (e.g. PLC, control module, etc.). The LP4 barrier system features an automatic self-diagnosis function that enables it to detect response time malfunctions (this time is declared for each model).

This safety system is permanently active and does not require any interventions from the outside. The TEST function is available should the user wish to check equipment connected downstream of the barrier (without physically entering the protected area). By means of this function the OSSDs can be switched from ON to OFF as long as the function remains active. Please see Table 6 for details about the use of the test function.

**The minimum duration of the TEST function must be 40 msec.**

**SAFETY MODULES MJB1 - MJB2 - MJB3 - MJB4**

LP4 light curtain can be integrated by the safety modules MJB1 - MJB2 - MJB3 and MJB4.

In fact they contain terminal boards, pre-wired connection, dip switches for the configuration choice and two safety relays connected to the light curtain outputs.

- **MJB1 - MJB3 operates with LP4 M (muting)** and has: RESTART push button, key selector for the Muting OVERRIDE, muting function active signaling lamp and two safety relays.
- **MJB2 - MJB4 operates with LP4 J (without muting)** and has: RESTART push button and two safety relays.

**EXAMPLE OF CONNECTION WITH EXTERNAL CONTACTORS K1/K2 WITH START/RESTART INTERLOCK ACTIVATED**



Figura 24



**In order to assure a correct barrier operation, it is necessary to connect the pins 2 and 4 of the Emitter according to table 6 (page 20) and to the "TEST FUNCTION" paragraph of page 26. For correct operation (in the case of LP4ER\_M without the use of Muting) the muting light must be connected (pin 1) and the Muting mode must be configured correctly (pin 7-8-9-10) following the indications in Table 13.**

LP4 SAFETY LIGHT CURTAIN

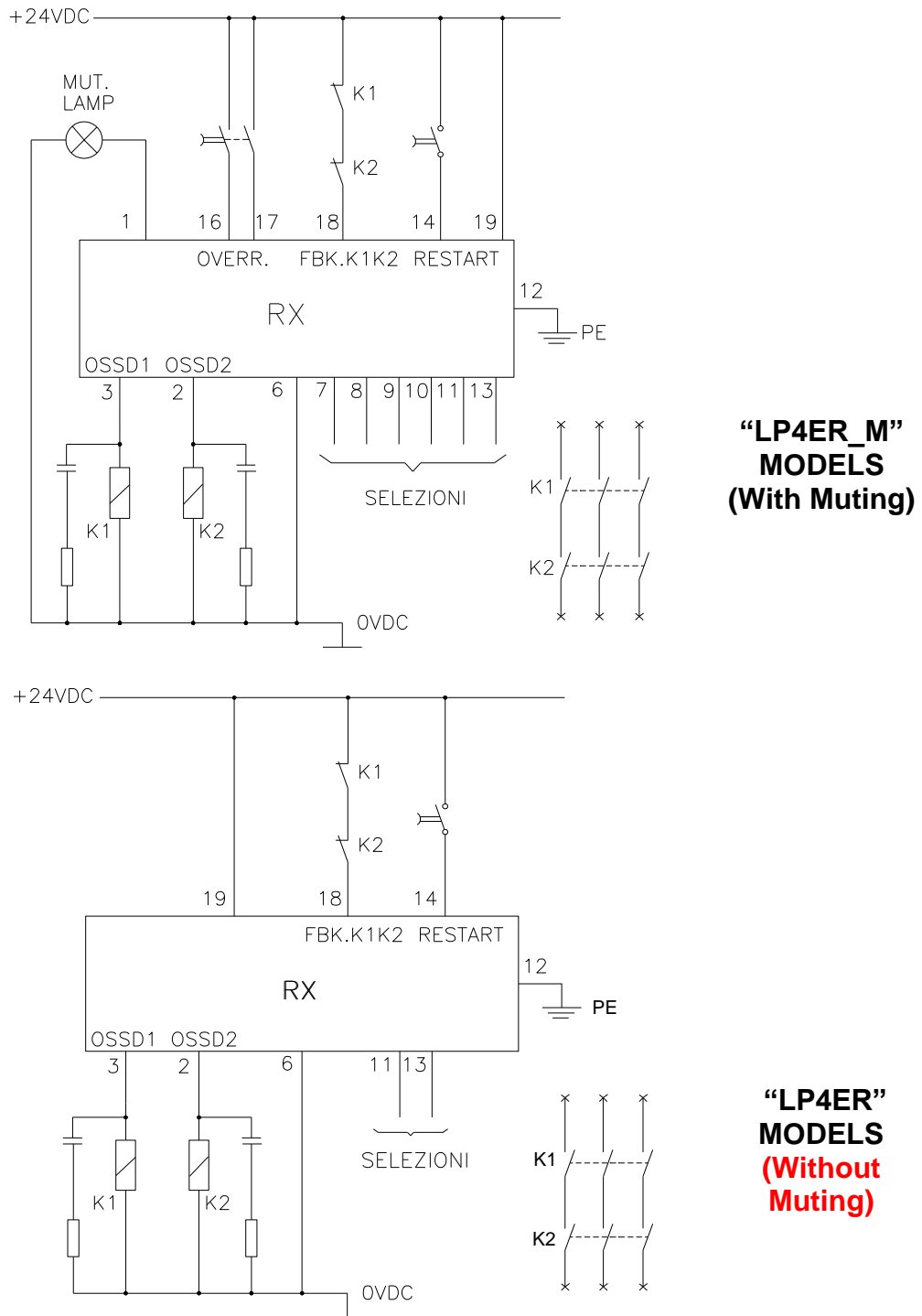
**EXAMPLE OF CONNECTION WITH AD SB300 WITH START/RESTART INTERLOCK ACTIVATED**



Figura 25

**In the protected area clear condition, the Receiver supplies a voltage of 24VDC on both outputs. The required load must therefore be connected between the output terminals and the 0VDC (Figure 26).**

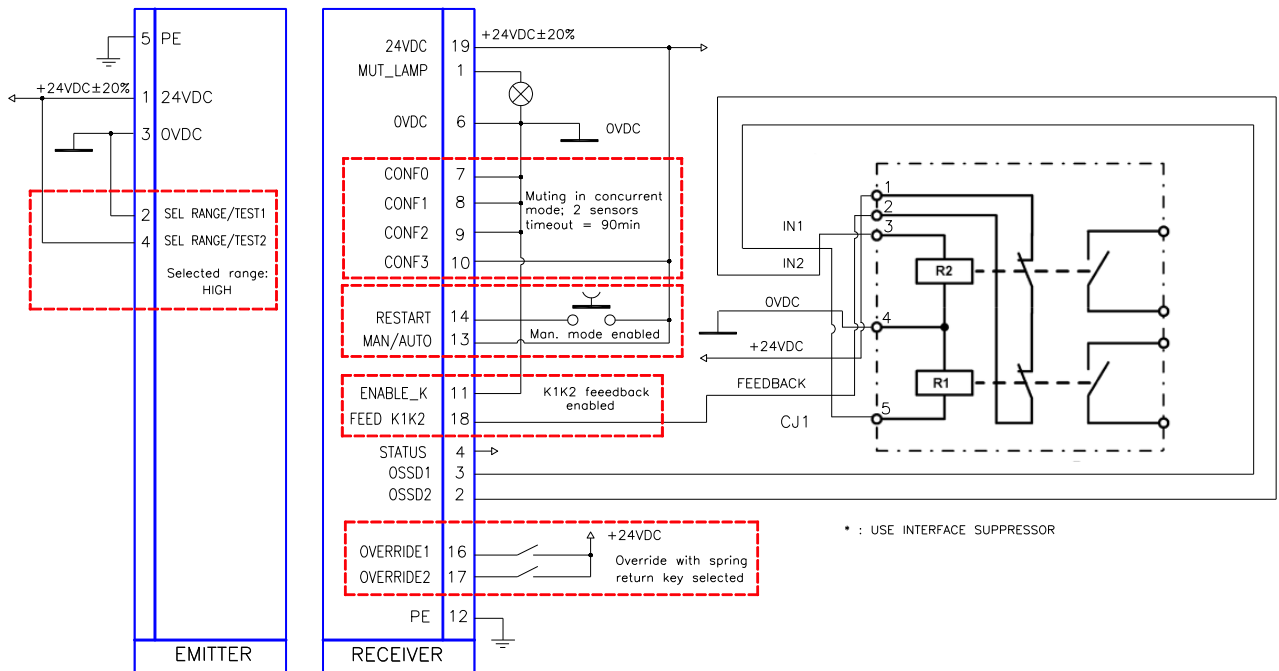
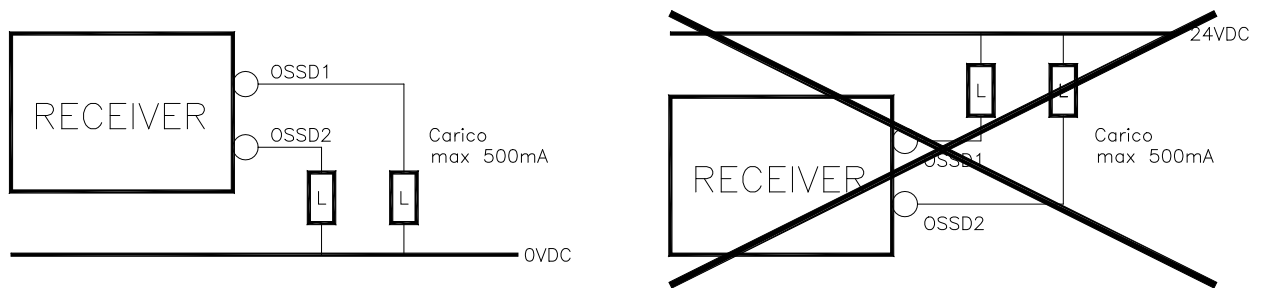

Figure 26

**MUTING STATUS AND LIGHT ("LP4ER\_M" MODELS)**

**Muting status must be highlighted to the outside using a indicator light close to the guarded opening.**

- ➔ LP4 is equipped with an output (pin 1 of connector M23 on the receiver) to which the indicator light can be connected and is able to monitor correct functioning of this and also that it is present.
- ➔ For a LP4ER\_M light curtain correct operation the muting lamp must be connected. When using LP4ER\_M without Muting function or Muting lamp, connect the receiver pin 1 to 0VDC (via a 10KΩ (1/4 W) resistor). If the muting lamp has a malfunction, the curtain switches to stop status indicating a FAIL on the display of the receiver.

English

## CONFIGURATION AND OPERATION MODES LP4ER\_L12

The LP4ER\_L12 operation mode is selected realizing appropriate connections on the M12 8 poles of the active element (Table 15 and Table 16).

### AUTOMATIC MODE

In this operation mode the OSSD1 and OSSD2 safety outputs follow the barrier status :

- with protected area clear, the safety outputs are active.
- with protected area intercepted, the safety outputs are disabled.

CONNECTION			OPERATION MODE
<b>EXT_SEL_A (PIN 5)</b> connected to : <b>ext_OSSD1 (PIN 1)</b>	<b>EXT_SEL_B (PIN 6)</b> connected to : <b>ext_OSSD2 (PIN 3)</b>	<b>EXT_K1_K2 (PIN 4)</b> connected to : <b>0VDC</b>	AUTOMATIC without K1-K2 feedback
<b>EXT_SEL_A (PIN 5)</b> connected to : <b>ext_OSSD2 (PIN 3)</b>	<b>EXT_SEL_B (PIN 6)</b> connected to : <b>ext_OSSD1 (PIN 1)</b>	<b>EXT_K1_K2 (PIN 4)</b> connected to : 24VDC (through series of contacts N.C. of external relays)	AUTOMATIC with K1-K2 feedback

Table 15

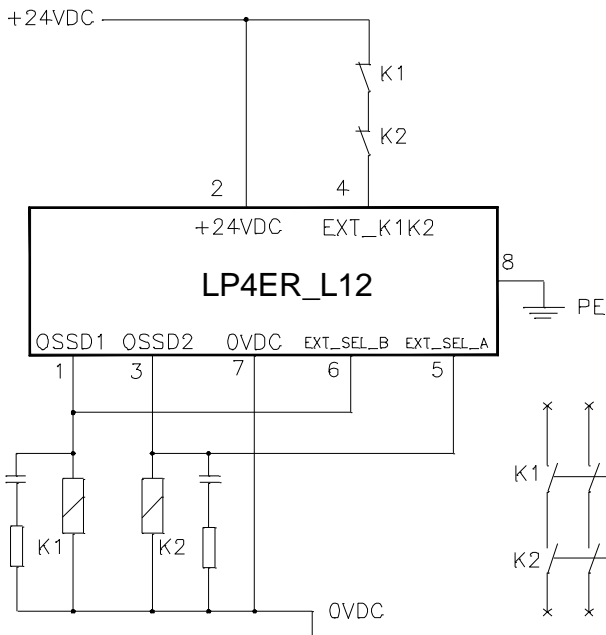

Example of connection of LP4ER\_L12 barrier in AUTOMATIC mode with feedback K1K2

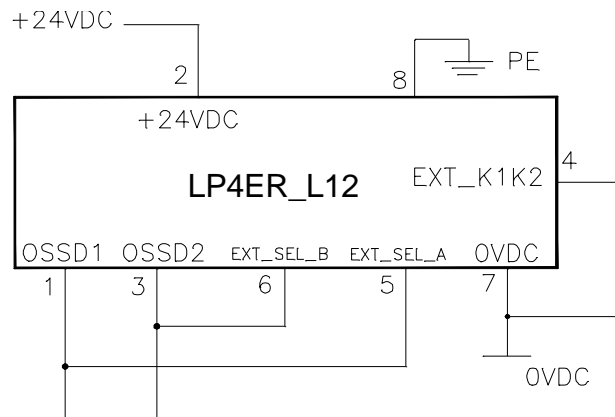

Example of connection of LP4ER\_L12 barrier in AUTOMATIC mode without feedback K1K2

**MANUAL MODE**

In this operating mode the safety outputs OSSD1 and OSSD2 are activated (+24VDC) only if the protected area is free and after the reception of the RESTART signal, using a push button or thank to an appropriate control on the SEL\_A or SEL\_B input (ref. Table ).

After an interception of the protected area, the safety outputs will be de-activated. To re-activate them it will be necessary to repeat the sequence described above.

The RESTART command is active with a voltage of +24VDC.  
 The minimum duration of the RESTART command is 400ms.

**⚠ Use of manual mode (start/restart interlock activated) is compulsory if the safety device controls an opening to protect a danger area and a person, after passing through the opening, may remain in the danger area without being detected (use as 'trip device' according to IEC 61496). Failure to comply with this rule may result in very serious hazards for the persons exposed.**

CONNECTION			OPERATION MODE
<b>EXT_SEL_A (PIN 5)</b> connected to : <b>24VDC (PIN 2)</b>	<b>EXT_SEL_B (PIN 6)</b> connected to : <b>24VDC (PIN 2)</b> (through the RESTART pushbutton)	<b>EXT_K1_K2 (PIN 4)</b> connected to : <b>0VDC</b>	MANUAL without feedback K1-K2
<b>EXT_SEL_A (PIN 5)</b> connected to : <b>24VDC (PIN 2)</b> (through the RESTART pushbutton)	<b>EXT_SEL_B (PIN 6)</b> connected to : <b>24VDC (PIN 2)</b>	<b>EXT_K1_K2 (PIN 4)</b> connected to : 24VDC (through series of contacts N.C. of external relays)	MANUAL with feedback K1-K2

Table 16

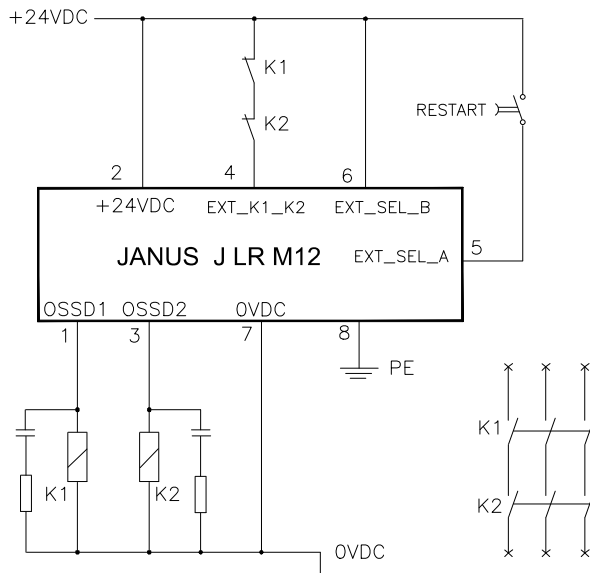

Example of connection of LP4ER\_L12 barrier in MANUAL mode with feedback K1K2

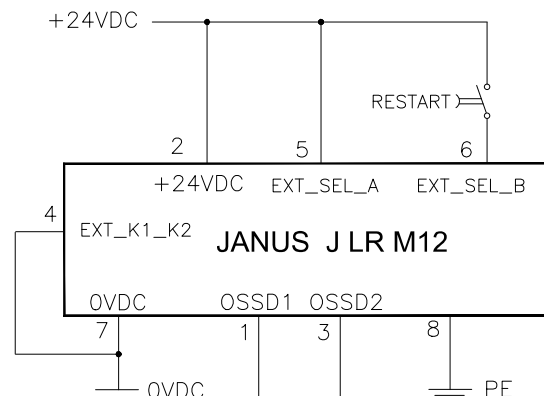

Example of connection of LP4ER\_L12 barrier in MANUAL mode without feedback K1K2

**DIMENSIONS**

The following tables shows the dimensions of the different LP4 models; refer to the drawings of pages 34 ÷ 36.

"LP4ER" MODELS									
DIMENSION	16m RANGE			LONG RANGE					
	2B	3B	4B	600	900	1200	2B	3B	4B
A (TX - RX)	736	1036	1136	736	1036	1336	736	1036	1136
B (Protected Area)	-	-	-	610	910	1210	-	-	-
C (First beam position)	120			76					

"LP4ER_M" MODELS																	
DIMENSION	16m RANGE												LONG RANGE				
	300	450	600	750	900	1050	1200	1350	1500	1650	1800	2B	3B	4B	2B	3B	4B
A (TX)	436	586	736	886	1036	1186	1336	1486	1636	1786	1936	736	1036	1136	736	1036	1136
A (RX)	476	626	776	926	1076	1226	1376	1526	1676	1826	1976	776	1076	1176	776	1076	1176
B (Protected Area)	310	460	610	760	910	1060	1210	1360	1510	1660	1810	-	-	-	-	-	-
C (First beam position)	72											120			76		

LP4ER\_M & LP4ER\_L

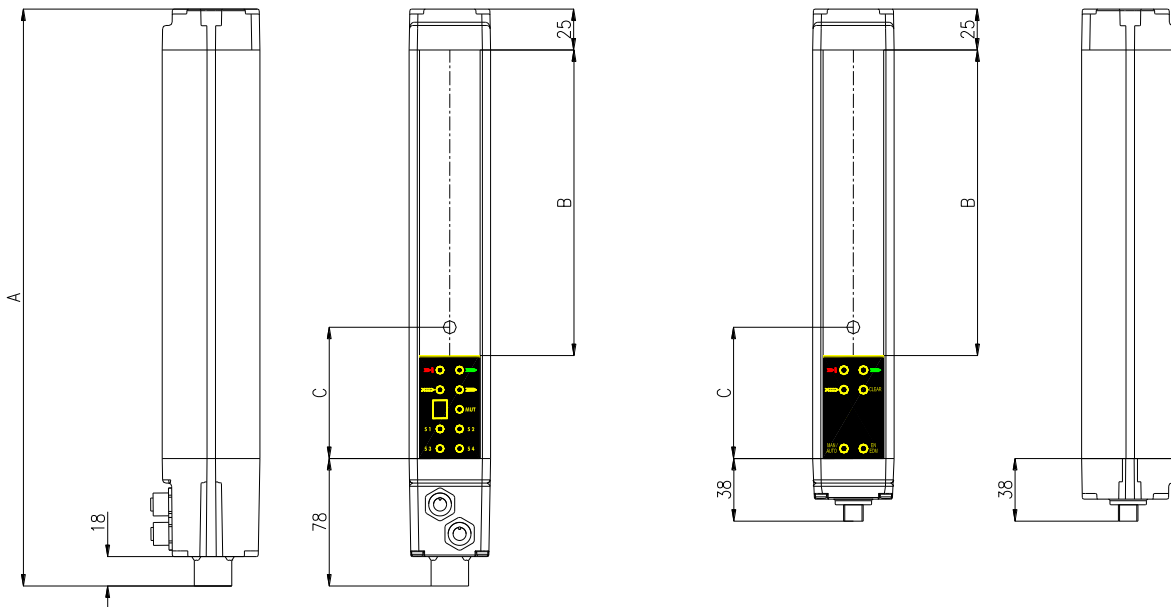
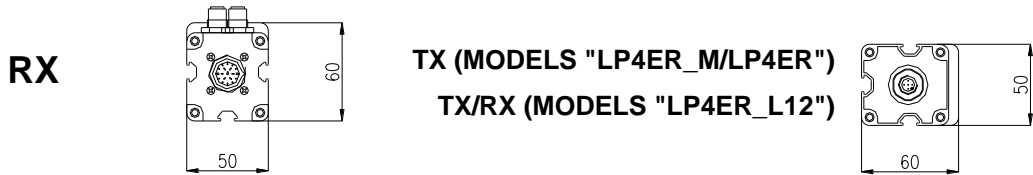

Figure 27

C: POSITION OF THE 1<sup>st</sup> ACTIVE BEAM

**TECHNICAL DATA**

GENERAL DATA		
Safety category		4
Response time	ms	≤ 30
Reset		automatic or manual selectable
Power supply	Vdc	24 ± 20%
Connections		Emitter M12 – 5 pins (male) Receiver M12 – 8 pins (male) Receiver M23 – 19 pins (male) * Muting sensors M12 – 5 pins (female)
Protection rating		IP 65
Max. length of electrical connections	m	100
Dimensions light curtain section	mm	50 x 60
Operating temperature	°C	-10 ÷ 55
Max operative humidity	%	95
Safety outputs		2 PNP auto-controlled – 500 mA @ 24 Vdc with short-circuit, overload, reversal of polarity protection
Max. output current	mA	500
Max. capacitive load	µF	2,2
Max. off-state voltage	V	< 1
Max. resistance of connections between OSSDs and the loads	Ohm	< 25
Light curtain status and weak signal outputs		PNP – 100 mA at 24 Vdc
Max. consumption	W	3 (Emitter)   6 (Receiver)
* Max current to Muting sensors (only MI models)	mA	100
* Muting lamp output		24Vdc / 0,5 ÷ 5 W
* Response time on Muting signals (sensors)	ms	100
* Muting max. time-out models ML - ML S2 - MT - MI with 2 sensors		30 sec or 90 min (selectable)
* Muting max. time-out models MI with 4 sensors - MT S4		30 sec or excludible (selectable)
* Override max. time-out	min	15 (renewable)
Light curtain lifetime		20 years
Safety level	Type 4	IEC 61496-1 IEC 61496-2
	SIL 3	IEC 61508
	SILCL 3	IEC 62061
	PL e - Cat.4	ISO 13849-1: 2015

- Specifications applicable only to models with Muting function

LP4ER_M SERIES	
Heights of guarded areas	mm 310 ÷ 1810 for light curtains with a resolution of 40 and 90 mm 310 ÷ 1210 for light curtains with a resolution of 30 mm
Resolution of light curtains for detecting upper or lower limbs	mm 30 – 40 - 90
Number of beams of light curtains for detection of body in access control	2 – 3 – 4
Operating range Low / High	m 0 ÷ 6 / 1 ÷ 16
Muting system	two-way with 2 or 4 sensors with max. concurrent time of 4 sec two-way sequential with 4 sensors
Muting sensors	external with relay or PNP output

LP4ER_M series Resolution 30 mm	303	453	603	753	903	1053	1203
Number of beams	16	24	32	40	48	56	64
Response time	ms 12	15	18	21	24	27	30
Overall barrier ht.	mm 476	626	776	926	1076	1226	1376
PFHd *	9,06E-09	9,98E-09	1,09E-08	1,18E-08	1,28E-08	1,37E-08	1,46E-08
DCavg #	98,24%	98,35%	98,44%	98,50%	98,55%	98,59%	98,63%
MTTFd #	years	100,00					
CCF #		80%					

LP4ER_M series Resolution 40 mm	304	454	604	754	904	1054	1204	1354	1504	1654	1804
Number of beams	10	15	20	25	30	35	40	45	50	55	60
Response time	ms 9,5	11	13	15	17	19	21	23	25	27	28,5
Overall barrier ht.	mm 476	626	776	926	1076	1226	1376	1526	1676	1826	1976
PFHd *	8,71E-09	9,45E-09	1,02E-08	1,10E-08	1,17E-08	1,25E-08	1,32E-08	1,40E-08	1,47E-08	1,55E-08	1,62E-08
DCavg #	98,19%	98,29%	98,37%	98,44%	98,49%	98,53%	98,57%	98,60%	98,63%	98,65%	98,67%
MTTFd #	years	100									
CCF #		80%									

\* IEC 61508

# ISO 13849-1: 2015

LP4ER_M series Resolution 90 mm	309	459	609	759	909	1059	1209	1359	1509	1659	1809
Number of beams	5	7	9	11	13	15	17	19	21	23	25
Response time	ms 7	8	9	10	10,5	11	12	13	13,5	14	15
Overall barrier ht.	mm 476	626	776	926	1076	1226	1376	1526	1676	1826	1976
PFHd *	8,91E-09	9,48E-09	1,01E-08	1,06E-08	1,12E-08	1,18E-08	1,24E-08	1,29E-08	1,35E-08	1,41E-08	1,47E-08
DCavg #	98,22%	98,30%	98,36%	98,41%	98,46%	98,50%	98,53%	98,56%	98,58%	98,61%	98,63%
MTTFd #	years	100									
CCF #		80%									

LP4ER_M – LP4ER_ML SERIES			
Number of beams of light curtains for detection of body in access control	2 – 3 – 4		
Operating range Low / High	m	8 ÷ 30 / 18 ÷ 60	
Muting system	Two-way with 2 or 4 sensors with max. concurrent actuation time 4 sec Two-way sequential with 4 sensors		
Muting Sensors	external with relay or PNP output		
LP4ER_M and LP4ER_ML SERIES	2B	3B	4B
Number of beams	2	3	4
Distance between beams	mm 500	400	300
Response time	ms 7	7	7
Overall barrier ht.	mm 776	1076	1176
PFHd *	7,53E-09	7,70E-09	7,87E-09
DCavg #	97,94%	97,99%	98,03%



LP4 SAFETY LIGHT CURTAIN

MTTFd #	years	100		
CCF #		80%		
<b>LP4ER_ML Resolution 40 mm</b>		<b>604</b>	<b>904</b>	<b>1204</b>
Number of beams		30	45	60
Response time	ms	17	23	28,5
Overall barrier ht.	mm	776	1076	1376
PFHd *		1,02E-08	1,17E-08	1,32E-08
DCavg #		98,37%	98,49%	98,57%
MTTFd #	years	100		
CCF #		80%		

LP4ER - LP4ER_L SERIES				
Heights of guarded areas	mm	310 ÷ 1810 for light curtains with a resolution of 40 mm		
Resolution of light curtains for detecting upper or lower limbs	mm	40		
Number of beams of light curtains for detection of body in access control		2 – 3 – 4		
Operating range Low / High (J models)	m	0 ÷ 6 / 1 ÷ 16		
Operating range Low / High (LP4ER_L models)	m	8 ÷ 30 / 18 ÷ 60		
<b>LP4ER - LP4ER_L SERIES</b>		<b>2B</b>	<b>3B</b>	<b>4B</b>
Number of beams		2	3	4
Distance between beams	mm	500	400	300
Response time	ms	7	7	7
Overall barrier ht.	mm	736	1036	1136
PFHd *		7,53E-09	7,70E-09	7,87E-09
DCavg #		97,94%	97,99%	98,03%
MTTFd #	years	100		
CCF #		80%		

LP4ER_L SERIES Resolution 40 mm	604	904	1204
Number of beams	30	45	60
Response time ms	17	23	28,5
Overall barrier ht. mm	736	1036	1336
PFHd *	1,02E-08	1,17E-08	1,32E-08
DCavg #	98,37%	98,49%	98,57%
MTTFd # years	100		
CCF #	80%		

\* IEC 61508

# ISO 13849-1: 2015

## CHECKS AND MAINTENANCE

### Verification of barrier efficiency.

- ⚡ Before each work shift or before switching on, check the correct operation of the photoelectric barrier.

Proceed as follows, intercepting the beams using the appropriate test object (available free of charge on request).

- ⚡ The correct test object must be used for testing, depending on the barrier resolution. Please see page 41 for the correct ordering code.

Refer to Figure 28:

- Introduce the test object into the protected area and move it slowly, starting from the top and moving down (or vice versa), first in the centre and then in the vicinity of both the Emitter and the Receiver.
- **Multibeam models:**  
Intercept each beam with an opaque object, first in the center of the detection zone and then close to the emitter and the receiver.
- Make sure that during each stage of the test object's movements the red LED on the Receiver is always on.

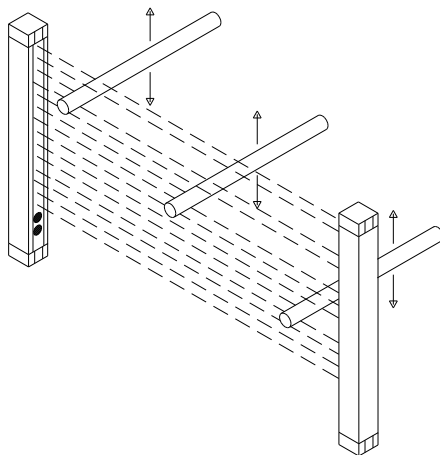

Figure 28

The LP4 barrier does not require any specific maintenance operations; however, periodic cleaning of the front protective surfaces of the Emitter and Receiver optics is recommended.

Wipe using a clean, damp cloth; in particularly dusty environments, after cleaning the front surface, the use of an anti-static spray is recommended.

**Never use abrasive or corrosive products, solvents or alcohol**, which could damage parts. Do not use woollen cloths, that could electrify the front surface.

- ⚡ Grooving or fine scratching of the front plastic surfaces can increase the amplitude of the emission angle of the light curtain, jeopardising detection efficiency in the presence of lateral reflecting surfaces.
- ⚡ This issue can also cause interference by muting sensors and jeopardise reliability of the system, also in absence of lateral reflecting surfaces.
- ⚡ It is therefore fundamental to pay particular attention during the cleaning phases of the curtain front window, especially in environments where abrasive dusts are present. (E.g. cement factories, etc).

If the ORANGE weak signal LED on the Receiver switches on (LED 1 in Figure 21), check that:

- the front surfaces are clean;
- the Emitter and Receiver are aligned correctly.

If the LED stays on, contact Datasensing S.r.l. Technical Service.

## TROUBLESHOOTING

The indications provided on the display of the Receiver make it possible to trace the cause of a system malfunction. As indicated in the “**INDICATIONS**” chapter of this manual, in the case of a fault, the system is blocked and a numeric code identifying the type of fault is shown on the display of the receiver. (See the table below). As soon as the error condition is removed, the code is cleared from the display and the system restarts automatically.

### EMITTER

LEDS (Flashing)	DIAGNOSIS	REMEDY
Red	Internal fault	Send the equipment for repair to Datasensing S.r.l. laboratories.
Red + Yellow	Internal fault	Send the equipment for repair to Datasensing S.r.l. laboratories.
Red + Green	Internal fault	Send the equipment for repair to Datasensing S.r.l. laboratories.
Red + Orange	Range selection error	Correct the range selection on the Emitter Unit

### RECEIVER

CODE (Flashing)	DIAGNOSIS	REMEDY	
<b>F</b>	Displayed alternatively to the error code		
<b>CONFIGURATION ERRORS</b>	<b>C</b>	Incorrect configuration of the system (the flashing led together with the C indicates the incorrect type of configuration) (ref. Table 4)	Check the connections according to configuration selected
	* <b>L</b>	Muting light not present or fault	Check that the MUTING lamp is present and working efficiently
	<b>U</b>	Incorrect "SYSTEM STATUS" or overload signal connection	Check the connection of terminal 4.
	<b>2</b>	OSSD outputs incorrectly connected to +24VDC	Carefully check the connection of terminals 2 and 3 (OSSD) on the connector. <b>Warning</b> : the load must be positioned between the MUTING function (OSSD) and 0 Vdc.
	<b>E</b>	External contact enabling/disabling signal missing or contactors feedback missing	Check the connections of terminals 11 and 18.
	<b>H</b>	Incorrect initial OVERRIDE configuration	Check the connections of terminals 16 and 17.
	* <b>II</b>	<ul style="list-style-type: none"> <li>Unstable Muting sensors signals</li> <li>Barrier configured for 2 sensors but found 3 or 4 sensors (the correspondent led flashes)</li> </ul>	<ul style="list-style-type: none"> <li>Check positioning of the muting sensors</li> <li>Verify the number of the sensors connected and the selected configuration</li> </ul>
<b>FAULTS</b>	<b>3</b>	Internal error	Send the equipment for repair to Datasensing S.r.l. laboratories.
	<b>4</b>	Internal error	Send the equipment for repair to Datasensing S.r.l. laboratories.
	<b>5</b>	Internal error on the OSSD outputs (or incorrect connection of these)	Carefully check the connection of terminals 2 and 3 (OSSD) on the connector. These terminals could be connected directly to + 24 Vdc or 0 Vdc. Otherwise, send the equipment for repair to Datasensing S.r.l. laboratories.
	<b>A</b>	Internal error	Send the equipment for repair to Datasensing S.r.l. laboratories.

\* Specifications applicable only to models with Muting function

CODE (Not flashing)	DIAGNOSIS	REMEDY
6	Short-circuit between the OSSD outputs	Carefully check the connection of terminals 2 and 3.
0	Overload of the OSSD outputs	Carefully check the connection of terminals 2 and 3 (OSSD) on the connector. If necessary, adjust load reducing the current required to max 500 mA (2.2 $\mu$ F)
1	Interfering Emitter detected (THE CODE REMAINS VISIBLE FOR AL LEAST 30s)	Carefully locate the interfering Emitter and take action in one of the following ways: <ul style="list-style-type: none"> <li>• Switch the position of the Emitter and Receiver</li> <li>• Move the interfering Emitter to avoid this illuminating the Receiver</li> <li>• Shield the beams coming from the interfering Emitter using opaque protections</li> </ul>
t (flashing)	Override with pulse command expired	Reset the system

**ACCESSORIES**

MODEL	DESCRIPTION
LP/BOX-1	Muting Junction Box
CD12M/0E-050A1	M12 female connectors 8 poles 5 m cable
CD12M/0E-100A1	M12 female connectors 8 poles 10 m cable
CD12M/0E-150A1	M12 female connectors 8 poles 15 m cable
CD12M/0E-250A1	M12 female connectors 8 poles 25 m cable
CD12M/0E-400A1	M12 female connectors 8 poles 40 m cable
CD12M/0E-050C1	M12 female connectors 8 poles 90° 5 m cable
CD12M/0E-100C1	M12 female connectors 8 poles 90° 10 m cable
CD12M/0E-150C1	M12 female connectors 8 poles 90° 15 m cable
CD23M/0R-030A1	M23 female connectors 19 poles 3 m cable
CD23M/0R-050A1	M23 female connectors 19 poles 5 m cable
CD23M/0R-100A1	M23 female connectors 19 poles 10 m cable
CD23M/0R-150A1	M23 female connectors 19 poles 15 m cable
CD23M/0R-200A1	M23 female connectors 19 poles 20 m cable
CRV-89	M23 female connectors 19 poles (not wired)
CD12M/0H-050A3	M12 female connector 5 poles 5 m cable
CD12M/0H-100A3	M12 female connector 5 poles 10 m cable
CD12M/0H-150A3	M12 female connector 5 poles 15 m cable
CD12M/0H-250A3	M12 female connector 5 poles 20 m cable
CD12M/0H-500A3	M12 female connector 5 poles 50 m cable
CD12M/0H-050C3	M12 female connector right angle 5 poles 5 m cable
CD12M/0H-100C3	M12 female connector right angle 5 poles 10 m cable
CD12M/0H-150C3	M12 female connector right angle 5 poles 15 m cable
CDP23/0R-030AC	3 m cable with 2 M23 female connectors
CDP23/0R-050AC	5 m cable with 2 M23 female connectors
CDP12/0H-100AC	10 m cable with 2 M12 female connectors
CDP12/0H-250AC	25 m cable with 2 M12 female connectors
ST 2230	30mm diameter test rod
ST 2240	40mm diameter test rod
ST 201 4	Set of 4 fastening brackets LL type
ST 201 6	Set of 6 fastening brackets LL type
ST 202 4	Set of 4 fastening brackets LH type
ST 203 4	Set of 4 fastening inserts
ST 203 6	Set of 6 fastening inserts

---

## COMPLIANCE

---

### European Declaration of Conformity

Hereby, Datasensing S.r.l. declares that the full text of the European Declaration of Conformity is available at: [www.datasensing.com](http://www.datasensing.com). Select the link from the downloads section of the product page.

### UKCA Declaration of Conformity

Hereby, Datasensing S.r.l. declares that the full text of the UKCA Declaration of Conformity is available at: [www.datasensing.com](http://www.datasensing.com). Select the link from the downloads section of the product page.

---

## GUARANTEE

---

All new LP4 systems are guaranteed by Datasensing S.r.l. for a period of 12 (twelve) months under normal working conditions, against defects due to faulty materials and workmanship.

During the aforesaid period, Datasensing S.r.l. promises to replace faulty parts free of charge. This guarantee covers both material and labour.

Datasensing S.r.l. reserves the right to decide whether to repair equipment or replace it with equipment of the same type or having the same characteristics.

The validity of this guarantee is subject to the following conditions:

- The user must notify Datasensing S.r.l. of the fault within twelve months following the date of delivery of the product.
- The equipment and all parts thereof must be in the condition in which they were supplied by Datasensing S.r.l.
- The defect or malfunction must not arise directly or indirectly from:
  - Improper use
  - Non-observance of the instructions for use;
  - Negligence, inexperience, improper maintenance;
  - Repairs, modifications and adjustments carried out by personnel not authorised by Datasensing S.r.l., tampering, etc.;
  - Accidents or collisions (also during transportation or due to acts of God);
  - Other reasons for which Datasensing S.r.l. cannot be held responsible.

Repairs will be carried out at Datasensing S.r.l. laboratories, to which the material must be consigned or forwarded: transport costs and any damage or loss of material during transportation will be charged to the Customer.

All replaced products and parts are property of Datasensing S.r.l.

Datasensing S.r.l. does not recognise any other form of guarantee or rights other than those expressly stated above; no requests for compensation for damages incurred for costs, suspension of activities or any other events or circumstances related in any way to malfunctioning of the product or any parts thereof will be taken into consideration.



Do not dispose of WEEE as mixed urban waste, arrange separate collection. Contact the appropriate authorized collection points or the manufacturer. (2012/19/UE)