

US50 SERIES - analogue output - ultrasonic sensors INSTRUCTION MANUAL

CONTROLS



Power ON LED (Green) – indicates the operating status of the sensor.

Status	Indicates
OFF	Power is OFF
Blinking @ 2Hz	Transmit disabled
ON stable	Sensor is operating normally

Signal LED (Red) – indicates the strength and condition of the sensor's incoming signal.

Status	Indicates
ON bright	Good signal
ON dim	Marginal signal strength
OFF	No signal is received, or target is beyond the sensor's range limitations

Output LEDs (Red or Yellow) – indicate the position of the target relative to the window limits.

Status	Indicates
ON Red (either)	In Teach mode; waiting for limit(s) to be taught
Min Analog ON yellow Max Analog ON yellow	Target is within analogue window limits
Min Analog ON yellow Max Analog flashing yellow	Target is outside max. window limit
Min Analog flashing yellow Max Analog ON yellow	Target is outside min. window limit
Min Analog OFF Max Analog OFF	No signal condition or outside operating limits

CONNECTIONS

5-POLE M12 CONNECTOR

BROWN 1	+	10 ... 30 VDC
BLUE 3	-	0 V
WHITE 2		ANALOGUE OUTPUT
BLACK 4		(4...20 mA / 0...10 V)
GREY 5		REMOTE TEACH

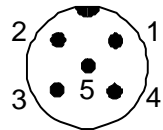

PRINCIPLES OF OPERATION

Ultrasonic sensors emit one or multiple pulses of ultrasonic energy, which travel through the air at the speed of sound. A portion of this energy reflects off the target and travels back to the sensor. The sensor measures the total time required for the energy to reach the target and return to the sensor. The distance to the object is then calculated using the following formula:

$$D = \frac{ct}{2}$$

D = Distance from the sensor to the target
C = Speed of sound in the air
T = Transit time for the ultrasonic pulse

To improve accuracy, an ultrasonic sensor may average the results of several pulses before outputting a new value.

Temperature effects

The speed of sound is dependent upon the composition, pressure and temperature of the gas in which it is traveling. For most ultrasonic applications, the composition and pressure of the gas are relatively fixed, while the temperature may fluctuate. In air, the speed of sound varies with temperature according to the following approximation:

$$C_{m/s} = 20 \sqrt{273 + T_c}$$

C_{m/s} = Speed of sound in meters per second
T_c = Temperature in °C

The speed of sound changes roughly 1% per 6° C (10° F). US50 series ultrasonic sensors have temperature compensation available, via the 8-pin DIP switch. Temperature compensation will reduce the error due to temperature by about 90%. NOTE: If the sensor is measuring across a temperature gradient, the compensation will be less effective.

TECHNICAL DATA

Power supply:	10 ... 30 VDC reverse polarity protection
Ripple:	≤ 2 Vpp
Consumption (load current excluded):	100mA max. at 10V 40mA max. at 30V
Ultrasonic frequency:	75 kHz burst, rep. rate 96 ms
Analogue output configuration:	Voltage sourcing: 0...10 VDC (Short-circuit protection) Min. load resistance = 500 Ω Min. required supply voltage for Full 0-10V Output Span = (1000/RLoad +13) VDC Current sourcing: 4...20mA Max load resistance = 1KΩ or (V supply/0.02-5) Ω whichever is lower Min. required supply voltage for full 4...20mA output span = 10VDC or [(RLoadx0.02)+5] VDC, whichever is greater. 4...20mA output calibrated at 25°C with a 250Ω load.
Response time:	100 ms to 2300 ms
Operating distance (typical values):	200...8000 mm
Temperature effect:	Uncompensated: 0.2% of distance /°C Compensated: 0.02% of distance /°C
Linearity:	± 0.2% of span from 200 to 8000 mm; ± 0.1% of span from 500 to 8000 mm (1mm min.)
Resolution:	1 mm
Minimum reading window size:	20 mm
Indicators:	Power ON LED (GREEN), Signal LED (RED), Output LED (bicolour YELLOW/RED)
Setting:	ANALOG push-button, remote command input (remote teach). Minimum and maximum detection limits can be programmed using the ANALOG push-button or remote input.
Remote input levels:	Connect grey wire to 0 to +2 VDC; impedance 12KΩ
Delay at Power On:	1.5 sec
Operating temperature:	-20 ... 70 °C
Storage temperature:	-20 ... 70 °C
Maximum relative humidity:	100%
Vibrations:	0.5 mm amplitude, 10...55 Hz frequency, for every axis (EN60068-2-6)
Shock resistance:	11 ms (30 G) shock for every axis (EN60068-2-27)
Reference standard:	EN60947-5-2
Housing material:	ABS polycarbonate
Push-button material:	Polyester
Mechanical protection:	IP67
Connections:	M12 5-poles connector
Weight:	260 g.

DIMENSIONS

dimensions in mm

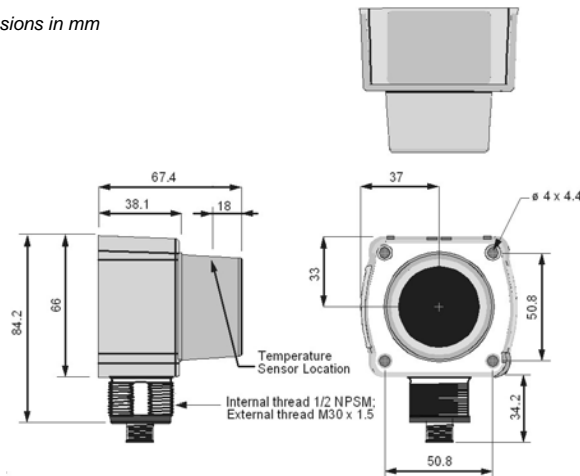

SENSOR PROGRAMMING

Two TEACH methods may be used to program the sensor: by teaching individual minimum and maximum limits, or by using the auto-window feature to center a sensing window around the taught position. The sensor may be programmed either via its two push buttons, or via a remote switch. Remote programming may also be used to disable the push buttons, preventing anyone on the production floor from adjusting any of the programming settings. To access this feature, connect the grey wire of the sensor to 0 - 2VDC, with a remote programming switch connected between them.

NOTE: The impedance of the Remote Teach input is 12 kΩ. Programming is accomplished by following the sequence of input pulses. The duration of each pulse (corresponding to a push-button "click"), and the period between multiple pulses, are defined as "T".

0.04 seconds < T < 0.8 seconds

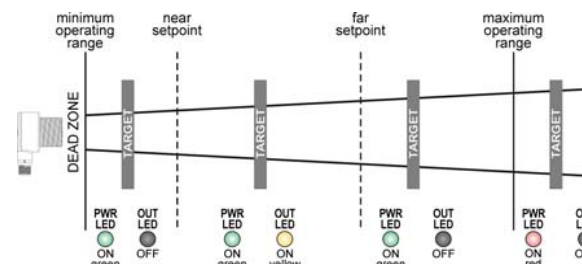

Positive or negative output slope programming

The sensor may be programmed for either a positive or a negative output slope, depending on which conditions are taught for the Min and Max Analog limits (Fig.1). If the Min Analogue limit is the Near Window setting and the Max Analogue limit is the Far Window setting, then the slope will be positive. If the opposite is true, then the slope will be negative.

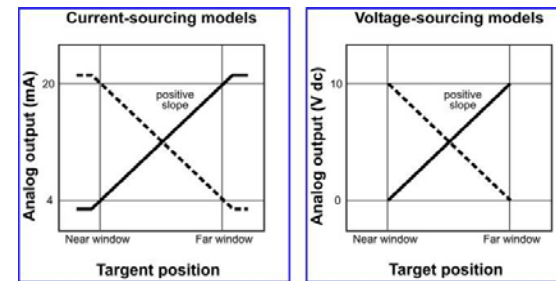

Fig.1

Configuration

The US50 features an 8-pin DIP switch bank for user setup. The DIP switches are located behind the access cover on the back of the sensor as shown in Fig.2/3. A spanner tool is included with each sensor for removing the cover.

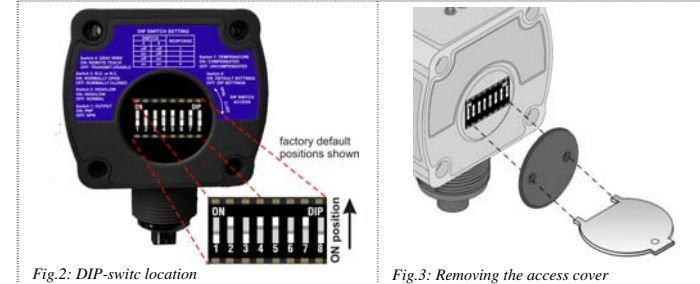

Fig.2: DIP-switch location

Fig.3: Removing the access cover

Tab.1: DIP Switch Settings

Switch	Function	Settings
1	Voltage/Current mode	ON = Current mode: 4 to 20 mA OFF* = Voltage mode: 0 to 10 VDC
2	Loss of echo	ON* = Min-Max mode OFF = Hold mode
3	Min-max	ON = Default to maximum output value on loss of echo OFF* = Default to minimum output value on loss of echo
4	Teach/Enable control	ON* = Configured for remote teach OFF = Configured for enable
5 and 6	Analogue voltage output response for 95% of step change 100 ms with 100 ms update 500 ms with 100 ms update* 1100 ms with 100 ms update 2300 ms with 100 ms update	Switch 5 OFF = Enabled ON* = Disabled
7	Temperature compensation	ON = Enabled OFF = Disabled
8	Factory calibration	ON = For factory calibration only; switch should be set to OFF for use OFF* = Dip-switch settings in control

* Factory default settings.

DIP-Switch selectable functions

Switch 1: Output Mode Select

ON = 4 to 20 mA current output is enabled
OFF = 0 to 10 VDC voltage output is enabled
Switch 1 configures the sensor internally to use either the current output or voltage output configuration.

Switch 2: Loss of Echo Mode Select

ON = Min-Max Mode
OFF = Hold Mode
Switch 2 determines the output response to the loss of echo. "Min-Max Mode" (Switch 2 ON) drives the output to either the minimum value or the maximum value when the echo is lost. (Minimum or Maximum value is selected via Switch 3.)
"Hold Mode" (Switch 2 OFF) maintains the output at the value which was present at the time of echo loss.

Switch 3: Min-Max Default

ON = Default to maximum output value at loss of echo (10.5V dc or 20.8 mA)
OFF = Default to minimum output value at loss of echo (0V dc or 3.6 mA)
Switch 3 selects the output response to loss of echo when "Min-Max Mode" is selected via Switch 2. When Switch 2 is OFF, Switch 3 has no function.

Switch 4: Teach/Transmit Enable Control

ON = Grey wire configured for remote teach
OFF = Grey wire configured for transmit enable/disable
High (5 to 30 VDC): Transmit Enabled (Power LED stable ON Green)
Low (0 to 2 VDC): Transmit Disabled (Power LED blinks at 2 Hz)
When Switch 4 is ON, the grey wire is used to teach window limits to the sensors.
When Switch 4 is OFF, the grey wire is used to enable and disable the sensor's transmit burst. The sensor output will react as if a "loss of echo" occurred and either hold the output or change to minimum or maximum value (depending on switch 2 and 3 settings). This function may be used when multiple sensors are in close proximity, which may make them vulnerable to crosstalk interference. A PLC can be used to enable the sensors one at a time to avoid crosstalk.

Switches 5 and 6: Response Speed Adjustment

Switches 5 and 6 are used to set the speed of the output response. The four values for response speed (see DIP switch settings Tab.1) relate to the number of sensing cycles over which the output value is averaged.

Switch 7: Temperature Compensation

ON = Temperature compensation enabled
OFF = Temperature compensation disabled
Changes in air temperature affect the speed of sound, which in turn affects the distance reading measured by the sensor. An increase in air temperature shifts both sensing window limits closer to the sensor. Conversely, a decrease in air temperature shifts both limits farther away from the sensor. This shift is approximately 3.5% of the limit distance for a 20° C change in temperature. With temperature compensation enabled (Switch 7 ON), the sensor will maintain the window limits to within 1.8 percent over the -20° to +70° C range.

The temperature sensor in the sensor's bezel cannot adapt to temperature change as quickly as an external temperature device can. When there are fast fluctuations in temperature, it may be best to use an external temperature monitor and feed its signal and the uncompensated distance measurement into a controller and perform the compensation calculations within the controller. Consult the factory for details on performing temperature compensation calculations.

NOTES:

- If temperature compensation is enabled, exposure to direct sunlight can affect the sensor's ability to accurately compensate for changes in temperature.
- With temperature compensation enabled, the temperature warmup drift upon powerup is less than 0.8% of the sensing distance. After 15 minutes, the apparent distance will be within 0.5% of the actual distance. After 30 minutes, the apparent distance will be within 0.3% of the actual distance.

Switch 8: Factory Calibration

ON = Factory calibration only
OFF = Normal operation

Teaching minimum and maximum limits

	Push-button		Remote line	
	Procedure	Result	Procedure 0.04 s. < T < 0.8 s.	Result
Min Analog Limit	Push and hold MIN ANALOG push-button	Min Analog LED turns ON Red; sensor is waiting for 0V or 4 mA limit.	Position the target for the Min Analog limit	Sensor learns the 0V or 4 mA limit Min Analog LED blinks red once
Min Analog Limit	Position the target for the Min Analog limit Press MIN ANALOG push-button	Sensor learns Min limit; Min LED changes from Red to Yellow or blinking Yellow	Single-pulse the remote line	
Max Analog Limit	Push and hold MAX ANALOG push-button	Max Analog LED turns ON Red; sensor is waiting for 10 VDC or 20 mA limit.	Position the target for the Max Analog limit	Sensor learns the 10 VDC or 20 mA limit Max Analog LED blinks red once
Max Analog Limit	Position the target for the Max Analog limit Press MAX ANALOG push-button	Sensor learns Max limit; Max LED changes from Red to Yellow or blinking Yellow	Double-pulse the remote line	

Using the Auto-Window feature

	Push-button		Remote line	
	Procedure	Result	Procedure 0.04 s. < T < 0.8 s.	Result
Min Analog Limit	Push and hold MIN ANALOG push-button	Min Analog LED turns ON Red	Position the target at the location where the midpoint of the window should be.	Min and Max LEDs both blink Red (0.5 second), then turn Yellow
Min Analog Limit	Press MAX ANALOG push-button	Max Analog LED turns ON Red (both the Min and Max Analog LEDs should now be ON)		
Max Analog Limit	Position the target at the location where the midpoint of the windows should be. Press either push-button	Its LED will blink Red	Triple-pulse the remote line	
Max Analog Limit	Press the other push-button	The Red Teach LEDs will change to Yellow and the sensor will return to RUN mode		

Push-button lockout

	Push-button		Remote line	
	Procedure	Result	Procedure 0.04 s. < T < 0.8 s.	Result
Push-button lockout	Not available via push-button	Not applicable	Four-pulse the remote line	Push-buttons are either enabled or disabled, depending on previous condition

General Notes on Programming

- The sensor will return to RUN mode if the limit is not registered within 120 seconds after entering TEACH Mode.
- Press and hold the programming push button > 2 seconds (before teaching the limit) to exit PROGRAM mode without saving any changes. The sensor will revert to the last saved program.
- If push buttons do not respond, perform remote lockout procedure to enable push buttons.

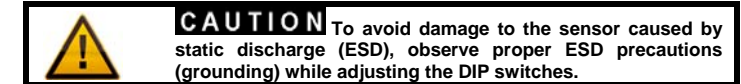

The sensors are NOT safety devices, and so MUST NOT be used in the safety control of the machines where installed.

Datalogic S.r.l.
Via S. Vitalino 13 - 40012 Calderara di Reno - Italy
Tel: +39 051 3147011 - Fax: +39 051 3147205 - www.datalogic.com

Helpful links at www.datalogic.com: **Contact Us, Terms and Conditions, Support.**

The warranty period for this product is 36 months. See General Terms and Conditions of Sales for further details.

Under current Italian and European laws, Datalogic is not obliged to take care of product disposal at the end of its life. Datalogic recommends disposing of the product in compliance with local laws or contacting authorised waste collection centres.

© 2010 - 2017 Datalogic S.p.A. and/or its affiliates • ALL RIGHTS RESERVED. • Without limiting the rights under copyright, no part of this documentation may be reproduced, stored in or introduced into a retrieval system, or transmitted in any form or by any means, or for any purpose, without the express written permission of Datalogic S.p.A. and/or its affiliates. Datalogic and the Datalogic logo are registered trademarks of Datalogic S.p.A. in many countries, including the U.S.A. and the E.U. All other trademarks and brands are property of their respective owners. Datalogic reserves the right to make modifications and improvements without prior notification.