

SERIE SM1

Tasteggio focalizzato

MANUALE ISTRUZIONI

CONTROLLI

LED Giallo (luce ricevuta)

- Il LED acceso stabilmente indica: uscita ON per sensori funzionanti in modalità LUCE.
- Il LED lampeggiante indica che il sensore sta lavorando con excess gain 1...1.5.

LED Verde

- Il LED acceso stabilmente indica che il sensore è alimentato.
- Il LED lampeggiante indica la presenza di un corto circuito sull'uscita.

INSTALLAZIONE

L'installazione del sensore può essere effettuata grazie ai 2 fori passanti del corpo, tramite due viti (M2x16 o di maggiore lunghezza) con rondelle e dadi di serraggio.

CONNESSIONI

Le connessioni sono configurate in conformità con la norma EN 60947-5-2.

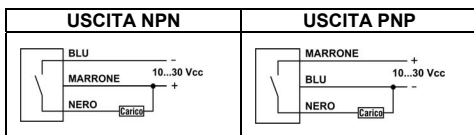

Datalogic S.r.l.

Via S. Vitalino 13 - 40012 Calderara di Reno - Italy
Tel: +39 051 3147011 - Fax: +39 051 3147205 -
www.datalogic.com

Link utili disponibili su www.datalogic.com: **Contatti, Termini e Condizioni, Supporto.**

Il periodo di garanzia per questo prodotto è di 36 mesi. Per maggiori dettagli vedere Condizioni Generali di Vendita su www.datalogic.com.

In base alle vigenti normative nazionali ed europee, Datalogic non è tenuta allo smaltimento del prodotto alla fine del ciclo di vita. Datalogic consiglia di smaltire gli apparecchi attenendosi alle normative nazionali vigenti in materia di smaltimento dei rifiuti o rivolgendosi agli appositi centri di conferimento.

© 2007 - 2017 Datalogic S.p.A. e/o le sue consociate • TUTTI I DIRITTI RISERVATI. • Senza con ciò limitare i diritti coperti dal copyright, nessuna parte della presente documentazione può essere riprodotta, memorizzata o introdotta in un sistema di recupero o trasmessa in qualsiasi forma o con qualsiasi mezzo, o per qualsiasi scopo, senza l'esplicito consenso scritto di Datalogic S.p.A. e/o delle sue consociate. Datalogic e il logo Datalogic sono marchi registrati di Datalogic S.p.A. depositati in diversi paesi, tra cui U.S.A. e UE. Tutti gli altri marchi registrati e brand sono di proprietà dei rispettivi proprietari. Datalogic si riserva il diritto di apportare modifiche e/o miglioramenti senza preavviso.

DIMENSIONI D'INGOMBRO / DIMENSIONS

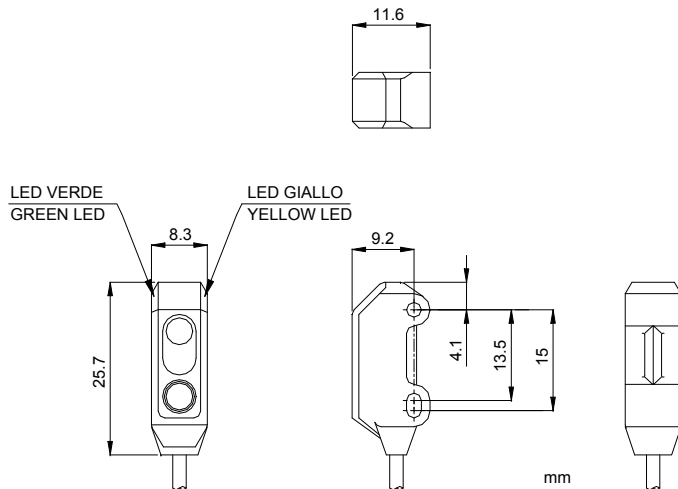

DATI TECNICI / TECHNICAL DATA

Tensione di alimentazione: <i>Power supply:</i>	10 ... 30 Vcc valori limite 10...30 Vdc limit values
Assorbimento: <i>Current consumption:</i>	25 mA max. (escluso il carico) (output current excluded)
Uscite: <i>Output:</i>	PNP o NPN (protezione contro il cortocircuito) PNP or NPN (short circuit protection)
Modalità di funzionamento: <i>Operating mode</i>	LUCE LIGHT
Corrente di uscita/Output current:	50 mA max.
Tensione di saturazione dell'uscita: <i>Output saturation voltage:</i>	< 0.25 V a 10 mA; < 0.5V a 50 mA < 0.25 V at 10 mA; < 0.5V at 50 mA
Tempo di risposta: <i>Response time:</i>	1 ms
Frequenza di commutazione: <i>Switching frequency:</i>	500 Hz
Indicatori:	LED GIALLO ON stabile = Luce ricevuta / Lampeggiante = Excess gain 1...1.5 LED VERDE ON stabile = Alimentazione attiva / Lampeggiante = Corto circuito sull'uscita Yellow LED ON steadily= light is sensed / flashing= marginal excess gain 1...1.5 Green LED ON steadily= power to sensor is ON / flashing= output overload
Temperatura di funzionamento: <i>Operative temperature:</i>	-20 ... 55 °C
Temperatura di immagazzinamento: <i>Storage temperature:</i>	-25 ... 70 °C
Protezione elettrica: <i>Electrical shock protection:</i>	Classe 2 Class 2
Distanza operativa (valori tipici): <i>Operating distance (typical values):</i>	3...20 mm (su Bianco 90%) 3...20 mm (on White 90%)
Tipo di emissione: <i>Emission type:</i>	Rossa (630 nm) Red (630 nm)
Vibrazioni: <i>Vibration:</i>	ampiezza 0.5 mm, frequenza 10 ... 55 Hz, per ogni asse (EN60068-2-6) 0.5 mm amplitude, 10 ... 55 Hz frequency, for every axis (EN60068-2-6)
Resistenza agli urti: <i>Shock resistance:</i>	11 ms (30 G) 6 shock per ogni asse (EN60068-2-27) 11 ms (30 G) 6 shock for every axis (EN60068-2-27)
Materiale contenitore: <i>Housing material:</i>	ABS
Materiale lenti: <i>lenses material:</i>	PMMA
Protezione meccanica: <i>Mechanical protection:</i>	IP67
Collegamenti/Connections:	cavo di lunghezza 2 m Ø 2.3 mm 3 fili / 2 m cable Ø 2.3 mm 3 wires
Peso/Weight:	16 g.

SM1 SERIES

Fixed Focus Proximity

INSTRUCTION MANUAL

CONTROLS

Yellow LED (LIGHT sensed)

- LED ON steadily means: output ON with sensors working in LIGHT mode.
- LED flashing means marginal excess gain 1...1.5.

Green LED

- LED ON steadily means power to sensor is ON.
- LED flashing means output overload.

INSTALLATION

The sensor can be positioned by means of the two housing's holes using two screws (M2x16 or longer) with nuts and washers.

CONNECTIONS

The connections are compliant to the EN 60947-5-2 standard.

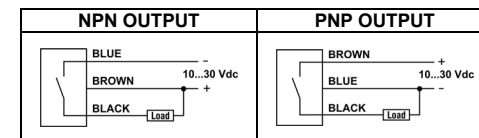

Datalogic S.r.l.

Via S. Vitalino 13 - 40012 Calderara di Reno - Italy
Tel: +39 051 3147011 - Fax: +39 051 3147205 -
www.datalogic.com

Helpful links at www.datalogic.com: **Contact Us, Terms and Conditions, Support.**

The warranty period for this product is 36 months. See General Terms and Conditions of Sales for further details.

Under current Italian and European laws, Datalogic is not obliged to take care of product disposal at the end of its life. Datalogic recommends disposing of the product in compliance with local laws or contacting authorised waste collection centres.

© 2007 - 2017 Datalogic S.p.A. and/or its affiliates • ALL RIGHTS RESERVED. • Without limiting the rights under copyright, no part of this documentation may be reproduced, stored in or introduced into a retrieval system, or transmitted in any form or by any means, or for any purpose, without the express written permission of Datalogic S.p.A. and/or its affiliates. Datalogic and the Datalogic logo are registered trademarks of Datalogic S.p.A. in many countries, including the U.S.A. and the E.U. All other trademarks and brands are property of their respective owners. Datalogic reserves the right to make modifications and improvements without prior notification.

SM1-SERIE

Reflexaster fokussiert

BEDIENUNGSANLEITUNG

ANZEIGE- UND BEDIENELEMENTE

gelbe LED (Licht empfangen)

- Die ständig aufleuchtende LED signalisiert: Ausgang ON bei hellschaltenden Sensoren.
- Die blinkende LED signalisiert, dass der Sensor mit 1...1.5 Funktionsreserve arbeitet.

grüne LED

- Die ständig aufleuchtende LED signalisiert Betriebsbereitschaft.
- Die blinkende LED signalisiert Ausgang überlastet.

INSTALLATION

Die Installation des Sensors erfolgt mit Hilfe von zwei Schrauben (M2X16 oder länger) mit Muttern und Unterlegscheiben über zwei Bohrungen am Gehäuse.

ANSCHLUSS

Der Anschluss entspricht der Norm EN 60947-5-2.

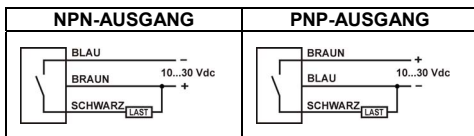

Datalogic S.r.l.

Via S. Vitalino 13 - 40012 Calderara di Reno - Italy
Tel: +39 051 3147011 - Fax: +39 051 3147205 - www.datalogic.com

Nützliche Links unter www.datalogic.com: **Kontakt, Terms and Conditions, Support.**

Die Gewährleistungsfrist für dieses Produkt beträgt 36 Monate. Für weitere Informationen siehe allgemeine Verkaufsbedingungen unter www.datalogic.com.

In Abhängigkeit der nationalen und europäischen Richtlinien ist Datalogic nicht zur Entsorgung des Produkts am Ende seiner Lebensdauer verpflichtet. Datalogic empfiehlt die Entsorgung der Geräte unter Einhaltung der nationalen Vorschriften bezüglich der Abfallentsorgung vorzunehmen oder sich diesbezüglich an die zuständigen Sammelanlagen zu wenden.

© 2007 - 2017 Datalogic S.p.A. und/oder die Tochtergesellschaften • ALLE RECHTE VORBEHALTEN. • Ohne die im Urheberrecht festgelegten Rechte einzuschränken, darf kein Teil dieses Dokuments ohne die ausdrückliche schriftliche Erlaubnis von Datalogic S.p.A. und/oder den Tochtergesellschaften vervielfältigt, in einem Datenabfragesystem gespeichert oder eingeführt oder in irgendeiner Form, mittels irgendwelcher Methode oder für irgendwelchen Zweck übermittelt werden. Datalogic und das Logo von Datalogic sind eingetragene Handelsmarken von Datalogic S.p.A. in vielen Ländern, einschließlich den USA und der EU. Alle sonstigen, angegebenen Marken und Produktbezeichnungen gehören den jeweiligen Eigentümern. Datalogic behält sich das Recht vor Modifikationen und Verbesserungen am Produkt jederzeit einzubringen.

ABMESSUNGEN / DIMENSIONS

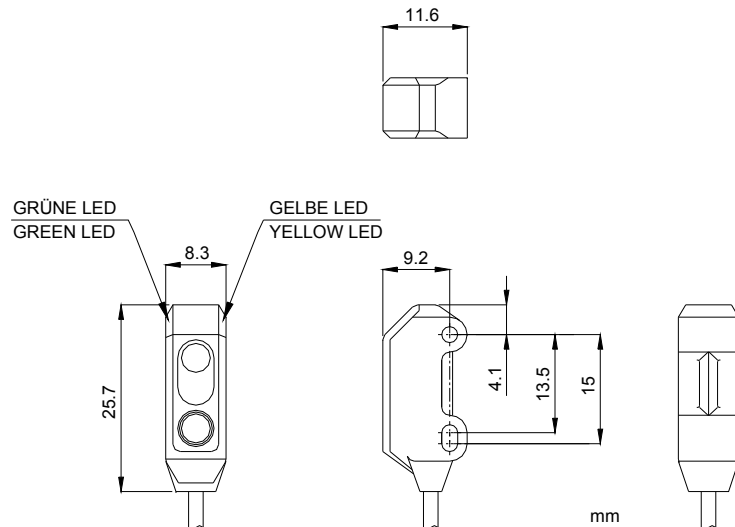

TECHNISCHE DATEN / TECHNICAL DATA

Betriebsspannung: <i>Power supply:</i>	10 ... 30 Vdc Grenzwerte <i>10...30 Vdc limit values</i>
Stromaufnahme: <i>Current consumption:</i>	25 mA max. (ohne Last) <i>output current excluded</i>
Ausgänge: <i>Output:</i>	PNP oder NPN (kurzschlussfest) <i>PNP or NPN (short circuit protection)</i>
Schaltungsart: <i>Operating mode</i>	HELL <i>LIGHT</i>
Ausgangsstrom/ <i>Output current:</i>	50 mA max.
Sättigungsspannung: <i>Output saturation voltage:</i>	< 0.25 V bei 10 mA; < 0.5 V bei 50 mA <i>< 0.25 V at 10 mA; < 0.5 V at 50 mA</i>
Ansprechzeit: <i>Response time:</i>	1 ms
Schaltfrequenz: <i>Switching frequency:</i>	500 Hz
Funktionsanzeige: <i>Indicators:</i>	gelbe LED ständig ON = Licht empfangen / blinkend = Funktionsreserve 1...1.5 grüne LED ständig ON = betriebsbereit / blinkend = Ausgang überlastet <i>Yellow LED ON steadily= light is sensed / flashing= marginal excess gain 1...1.5</i> <i>Green LED ON steadily= power to sensor is ON / flashing= output overload</i>
Betriebstemperatur: <i>Operative temperature:</i>	-20...55 °C
Lagertemperatur: <i>Storage temperature:</i>	-25...70 °C
Schutzklasse: <i>Electrical shock protection:</i>	Klasse 2 <i>Class 2</i>
Tastweite (typische Werte): <i>Operating distance (typical values):</i>	3...20 mm (auf weiss 90%) <i>3...20 mm (on White 90%)</i>
Sender, Wellenlänge: <i>Emission type:</i>	rot (630 nm) <i>Red (630 nm)</i>
Vibration: <i>Vibration:</i>	Amplitude 0.5 mm, Frequenz 10 ... 55 Hz, pro Achse (EN60068-2-6) <i>0.5 mm amplitude, 10 ... 55 Hz frequency, for every axis (EN60068-2-6)</i>
Schockbeständigkeit: <i>Shock resistance:</i>	11 ms (30 G) 6 Schocks pro Achse (EN60068-2-27) <i>11 ms (30 G) 6 shock for every axis (EN60068-2-27)</i>
Gehäusematerial: <i>Housing material:</i>	ABS
Linienmaterial: <i>lenses material:</i>	PMMA
Schutzart: <i>Mechanical protection:</i>	IP67
Anschluss/Connections:	2 m Kabel, Ø 2.3 mm, 3 Adern / 2 m cable Ø 2.3 mm 3 wires
Gewicht/Weight:	16 g

SM1 SERIES

Fixed Focus Proximity

INSTRUCTION MANUAL

CONTROLS

Yellow LED (LIGHT sensed)

- LED ON steadily means: output ON with sensors working in LIGHT mode.
- LED flashing means marginal excess gain 1...1.5.

Green LED

- LED ON steadily means power to sensor is ON.
- LED flashing means output overload.

INSTALLATION

The sensor can be positioned by means of the two housing's holes using two screws (M2x16 or longer) with nuts and washers.

CONNECTIONS

The connections are compliant to the EN 60947-5-2 standard.

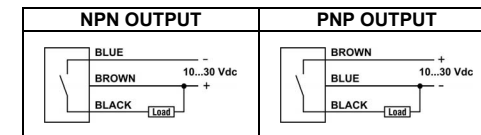

Datalogic S.r.l.

Via S. Vitalino 13 - 40012 Calderara di Reno - Italy
Tel: +39 051 3147011 - Fax: +39 051 3147205 - www.datalogic.com

Helpful links at www.datalogic.com: **Contact Us, Terms and Conditions, Support.**

The warranty period for this product is 36 months. See General Terms and Conditions of Sales for further details.

Under current Italian and European laws, Datalogic is not obliged to take care of product disposal at the end of its life. Datalogic recommends disposing of the product in compliance with local laws or contacting authorised waste collection centres.

© 2007 - 2017 Datalogic S.p.A. and/or its affiliates • ALL RIGHTS RESERVED. • Without limiting the rights under copyright, no part of this documentation may be reproduced, stored in or introduced into a retrieval system, or transmitted in any form or by any means, or for any purpose, without the express written permission of Datalogic S.p.A. and/or its affiliates. Datalogic and the Datalogic logo are registered trademarks of Datalogic S.p.A. in many countries, including the U.S.A. and the E.U. All other trademarks and brands are property of their respective owners. Datalogic reserves the right to make modifications and improvements without prior notification.

CONTROLLI

LED Giallo (luce ricevuta)

- Il LED acceso stabilmente indica: uscita ON per sensori funzionanti in modalità LUCE uscita OFF per sensori funzionanti in modalità BUIO.
- Il LED lampeggiante indica che il sensore sta lavorando con excess gain 1...1.5 (solo per SM2-PR-2-F00-xD).

LED Verde

- Il LED acceso stabilmente indica che il sensore è alimentato.
- Il LED lampeggiante indica la presenza di un corto circuito sull'uscita.

INSTALLAZIONE

L'installazione del sensore può essere effettuata grazie ai 2 fori passanti del corpo, tramite due viti (M2x10 o di maggiore lunghezza) con rondelle e dadi di serraggio.

CONNESSIONI

Le connessioni sono configurate in conformità con la norma EN 60947-5-2.

SM2-PR-D00-xL / SM2-PR-2-F00-xD

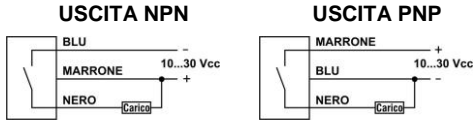

SM2-PR-2-G00-XX

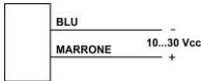

Datalogic S.r.l.
Via S. Vitalino 13 - 40012 Calderara di Reno - Italy
Tel: +39 051 3147011 - Fax: +39 051 3147205 - www.datalogic.com

Link utili disponibili su www.datalogic.com: **Contatti, Termini e Condizioni, Supporto.**

Il periodo di garanzia per questo prodotto è di 36 mesi. Per maggiori dettagli vedere Condizioni Generali di Vendita su www.datalogic.com.

Datalogic consiglia di smaltire gli apparecchi attenendosi alle normative nazionali vigenti in materia di smaltimento dei rifiuti o rivolgendosi agli appositi centri di conferimento.

© 2007 - 2019 Datalogic S.p.A. e/o le sue consociate • TUTTI I DIRITTI RISERVATI. • Senza con ciò limitare i diritti coperti dal copyright, nessuna parte della presente documentazione può essere riprodotta, memorizzata o introdotta in un sistema di recupero o trasmessa in qualsiasi forma o con qualsiasi mezzo, o per qualsiasi scopo, senza l'espreso consenso scritto di Datalogic S.p.A. e/o delle sue consociate. Datalogic e il logo Datalogic sono marchi registrati di Datalogic S.p.A. depositati in diversi paesi, tra cui U.S.A. e UE. Tutti gli altri marchi registrati e brand sono di proprietà dei rispettivi proprietari. Datalogic si riserva il diritto di apportare modifiche e/o miglioramenti senza preavviso.

DIMENSIONI D'INGOMBRO / DIMENSIONS

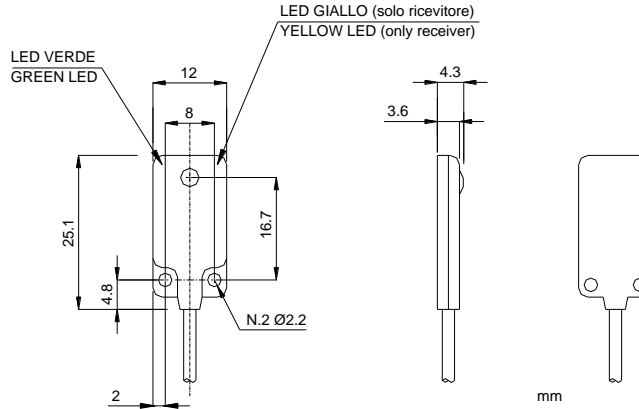

DATI TECNICI / TECHNICAL DATA

Tensione di alimentazione: <i>Power supply:</i>	10 ... 30 Vcc valori limite <i>limit values</i>
Assorbimento: <i>Current consumption:</i>	25 mA max. (escluso il carico) <i>(output current excluded)</i>
Uscite: <i>Output:</i>	PNP o NPN (protezione contro il cortocircuito) <i>PNP or NPN (short circuit protection)</i>
Modalità di funzionamento: <i>Operating mode</i>	LUCE (SM2-PR-2-D00-xL) / BUIO (SM2-PR-2-F00-xD) <i>LIGHT (SM2-PR-2-D00-xL) / DARK (SM2-PR-2-F00-xD)</i>
Corrente di uscita: <i>Output current</i>	50 mA max.
Tensione di saturazione dell'uscita: <i>Output saturation voltage:</i>	< 0.25 V a 10 mA; < 0.5 V a 50 mA <i>< 0.25 V at 10 mA; < 0.5 V at 50 mA</i>
Tempo di risposta: <i>Response time:</i>	1 ms
Frequenza di commutazione: <i>Switching frequency:</i>	500 Hz
Indicatori: <i>Indicators:</i>	LED GIALLO ON stabile = luce ricevuta Lampeggiante = Excess gain 1...1.5 (solo SM2-PR-2-F00-xD) LED VERDE ON stabile = Alimentazione attiva Lampeggiante = Corto circuito sull'uscita YELLOW LED ON steadily = light is sensed flashing = marginal excess gain 1...1.5 (only SM2-PR-2-F00-xD) GREEN LED ON steadily = power to sensor is ON flashing = output overload
Temperatura di funzionamento: <i>Operating temperature:</i>	-20 ... 55 °C
Temperatura di immagazzinamento: <i>Storage temperature:</i>	-25 ... 70 °C
Protezione elettrica: <i>Electrical shock protection:</i>	Classe 2 / Class 2
Distanza operativa (valori tipici): <i>Operating distance (typical values):</i>	3...170 mm (su Bianco 90%) / on White 90% (SM2-PR-2-D00-xL) 0...1.2 m (SM2-PR-2-FG00-xD)
Tipo di emissione: <i>Emission type:</i>	Rossa / RED (660 nm)
Vibrazioni: <i>Vibration:</i>	ampiezza 0.5 mm, frequenza 10 ... 55 Hz, per ogni asse (EN60068-2-6) 0.5 mm amplitude, 10 ... 55 Hz frequency, for every axis (EN60068-2-6)
Resistenza agli urti: <i>Shock resistance:</i>	11 ms (30 G) 6 shock per ogni asse (EN60068-2-27) 11 ms (30 G) 6 shock for every axis (EN60068-2-27)
Materiale contenitore: <i>Housing material:</i>	ABS
Materiale lenti: <i>lenses material:</i>	PMMA
Protezione meccanica: <i>Mechanical protection:</i>	IP67
Collegamenti / Connections:	cavo 2 m Ø 2.3 mm 3 fili / 2 m cable Ø 2.3 mm 3 wires (SM2-PR-2-D00-xL/SM2-PR-2-F00-xD) cavo 2 m Ø 2.3 mm 2 fili / 2 m cable Ø 2.3 mm 2 wires (SM2-PR-2-G00-xx)
Peso/Weight:	16 g.



CONTROLS

Yellow LED (LIGHT sensed)

- LED ON steadily means: output ON with sensors working in LIGHT mode output OFF with sensors working in DARK mode.
- LED flashing means marginal excess gain 1...1.5 (only for SM2-PR-2-F00-xD).

Green LED

- LED ON steadily means power to sensor is ON.
- LED flashing means output overload.

INSTALLATION

The sensor can be positioned by means of the two housing's holes using two screws (M2x10 or longer) with nuts and washers.

CONNECTIONS

The connections are compliant to the EN 60947-5-2 standard.

SM2-PR-D00-xL / SM2-PR-2-F00-xD

NPN OUTPUT

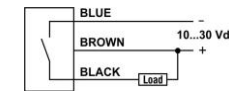

PNP OUTPUT

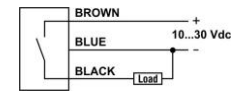

SM2-PR-2-G00-XX

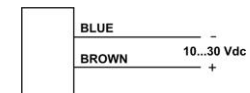

Datalogic S.r.l.
Via S. Vitalino 13 - 40012 Calderara di Reno - Italy
Tel: +39 051 3147011 - Fax: +39 051 3147205 - www.datalogic.com

Helpful links at www.datalogic.com: **Contact Us, Terms and Conditions, Support.**

The warranty period for this product is 36 months. See General Terms and Conditions of Sales for further details.

Datalogic recommends disposing of the product in compliance with local laws or contacting authorised waste collection centres.

© 2007 - 2019 Datalogic S.p.A. and/or its affiliates • ALL RIGHTS RESERVED. • Without limiting the rights under copyright, no part of this documentation may be reproduced, stored in or introduced into a retrieval system, or transmitted in any form or by any means, or for any purpose, without the express written permission of Datalogic S.p.A. and/or its affiliates. Datalogic and the Datalogic logo are registered trademarks of Datalogic S.p.A. in many countries, including the U.S.A. and the E.U. All other trademarks and brands are property of their respective owners. Datalogic reserves the right to make modifications and improvements without prior notification.

SM2-SERIE

Reflexfokussiert/Einweglichtschranke

BEDIENUNGSANLEITUNG

ANZEIGE- UND BEDIENELEMENTE

gelbe LED (Licht empfangen)

- Die ständig aufleuchtende LED signalisiert: Ausgang ON bei hellerschaltenden Sensoren, Ausgang OFF bei dunkelschaltenden Sensoren.
- Die blinkende LED signalisiert, dass der Sensor mit 1...1.5 Funktionsreserve arbeitet (nur bei SM2-PR-2-F00-xD).

grüne LED

- Die ständig aufleuchtende LED signalisiert Betriebsbereitschaft.
- Die blinkende LED signalisiert Ausgang überlastet.

INSTALLATION

Die Installation des Sensors erfolgt mit Hilfe von zwei Schrauben (M2X10 oder länger) mit Muttern und Unterlegscheiben über zwei Bohrungen am Gehäuse.

ANSCHLUSS

Der Anschluss entspricht der Norm EN 60947-5-2.

SM2-PR-D00-xL / SM2-PR-2-F00-xD

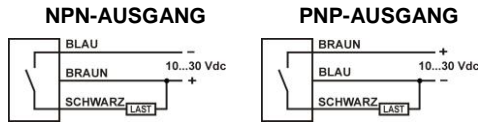

SM2-PR-2-G00-XX



Datalogic S.r.l.

Via S. Vitalino 13 - 40012 Calderara di Reno - Italy
Tel: +39 051 3147011 - Fax: +39 051 3147205 - www.datalogic.com

Nützliche Links unter www.datalogic.com: **Kontakt, Terms and Conditions, Support.**

Die Gewährleistungsfrist für dieses Produkt beträgt 36 Monate. Für weitere Informationen siehe allgemeine Verkaufsbedingungen unter www.datalogic.com.

Datalogic empfiehlt die Entsorgung der Geräte unter Einhaltung der nationalen Vorschriften bezüglich der Abfallentsorgung vorzunehmen oder sich diesbezüglich an die zuständigen Sammeleinrichtungen zu wenden.

© 2007 - 2019 Datalogic S.p.A. und/oder die Tochtergesellschaften • ALLE RECHTE VORBEHALTEN. • Ohne die im Urheberrecht festgelegten Rechte einzuschränken, darf kein Teil dieses Dokuments ohne die ausdrückliche schriftliche Erlaubnis von Datalogic S.p.A. und/oder den Tochtergesellschaften vervielfältigt, in einem Datenabfragesystem gespeichert oder eingeführt oder in irgendeiner Form, mittels irgendwelcher Methode oder für irgendwelchen Zweck übermittelt werden. Datalogic und das Logo von Datalogic sind eingetragene Handelsmarken von Datalogic S.p.A. in vielen Ländern, einschließlich den USA und der EU. Alle sonstigen, angegebenen Marken und Produktzeichnungen gehören den jeweiligen Eigentümern. Datalogic behält sich das Recht vor Modifikationen und Verbesserungen am Produkt jederzeit einzubringen.

ABMESSUNGEN / DIMENSIONS

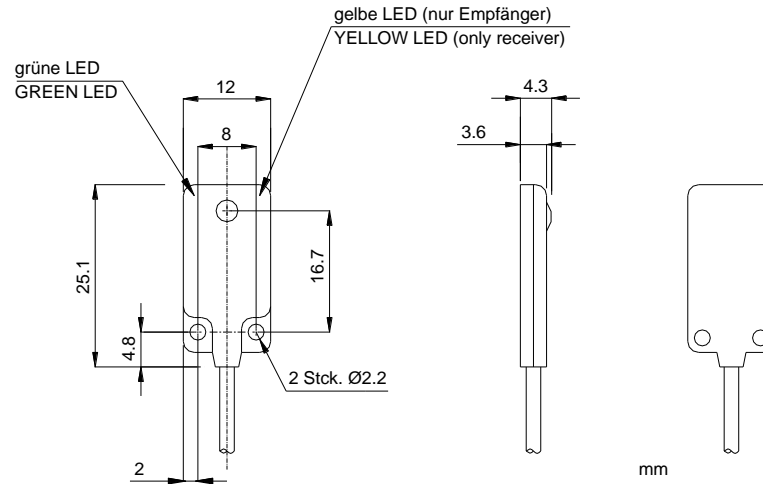

TECHNISCHE DATEN / TECHNICAL DATA

Betriebsspannung / Power supply:	10 ... 30 Vdc Grenzwerte / limit values	
Stromaufnahme:	25 mA max. (ohne Last)	
Current consumption:	(output current excluded)	
Ausgänge:	PNP oder NPN (kurzschlussfest)	
Output:	PNP or NPN (short circuit protection)	
Schaltungsart:	HELL (SM2-PR-2-D00-xL) / DUNKEL (SM2-PR-2-F00-xD)	
Operating mode:	LIGHT (SM2-PR-2-D00-xL) / DARK (SM2-PR-2-F00-xD)	
Ausgangsstrom/Output: current:	50 mA max.	
Sättigungsspannung:	< 0.25 V bei 10 mA; < 0.5 V bei 50 mA	
Output saturation voltage:	< 0.25 V at 10 mA; < 0.5 V at 50 mA	
Ansprechzeit/Response time:	1 ms	
Schaltfrequenz:	500 Hz	
Switching frequency:		
Funktionsanzeige:	Gelbe LED	ständig ON = Licht empfangen blinkend = Funktionsreserve 1...1.5 (nur bei SM2-PR-2-F00-xD)
Indicators:	grüne LED	ständig ON = betriebsbereit blinkend = Ausgang überlastet
	YELLOW LED	ON steady= light is sensed flashing= marginal excess gain 1...1.5 (only SM2-PR-2-F00-xD)
	GREEN LED	ON steady= power to sensor is ON flashing= output overload
Betriebstemperatur:	-20...55 °C	
Operating temperature:		
Lagertemperatur:	-25...70 °C	
Storage temperature:		
Schutzklasse:	Klasse 2	
Electrical shock protection:		
Reichweite (typische Werte):	3...170 mm (auf weiss 90%) / on White 90% (SM2-PR-2-D00-xL)	
Operating distance (typical values):	0...1.2 m (SM2-PR-2-FG00-xD)	
Sender, Wellenlänge:	rot / RED (660 nm)	
Emission type:		
Vibration:	Amplitude 0.5 mm, Frequenz 10 ... 55 Hz, pro Achse (EN60068-2-6)	
Vibration:	0.5 mm amplitude, 10 ... 55 Hz frequency, for every axis (EN60068-2-6)	
Schockbeständigkeit:	11 ms (30 G) 6 Schocks pro Achse (EN60068-2-27)	
Shock resistance:	11 ms (30 G) 6 shock for every axis (EN60068-2-27)	
Gehäusematerial:	ABS	
Housing material:		
Linse/material/lenses material:	PMMA	
Schutzart/Mechanical protection:	IP67	
Anschluss / Connections:	Kabel, 2 m Ø 2.3 mm 3 Adern / 2 m cable Ø 2.3 mm 3 wires (SM2-PR-2-D00-xL/SM2-PR-2-F00-xD)	
	Kabel 2 m Ø 2.3 mm 3 Adern / 2 m cable Ø 2.3 mm 2 wires (SM2-PR-2-G00-xx)	
Gewicht/Weight:	16 g.	

SM2 SERIES

Fixed Focus Proximity / Through beam

INSTRUCTION MANUAL

CONTROLS

Yellow LED (LIGHT sensed)

- LED ON steadily means: output ON with sensors working in LIGHT mode, output OFF with sensors working in DARK mode.
- LED flashing means marginal excess gain 1...1.5 (only for SM2-PR-2-F00-xD).

Green LED

- LED ON steadily means power to sensor is ON.
- LED flashing means output overload.

INSTALLATION

The sensor can be positioned by means of the two housing's holes using two screws (M2x10 or longer) with nuts and washers.

CONNECTIONS

The connections are compliant to the EN 60947-5-2 standard.

SM2-PR-D00-xL / SM2-PR-2-F00-xD

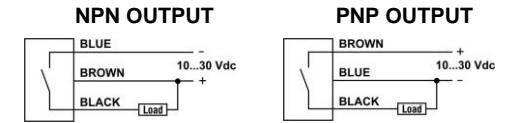

SM2-PR-2-G00-XX

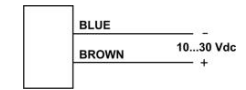

Datalogic S.r.l.

Via S. Vitalino 13 - 40012 Calderara di Reno - Italy
Tel: +39 051 3147011 - Fax: +39 051 3147205 - www.datalogic.com

Helpful links at www.datalogic.com: **Contact Us, Terms and Conditions, Support.**

The warranty period for this product is 36 months. See General Terms and Conditions of Sales for further details.

Datalogic recommends disposing of the product in compliance with local laws or contacting authorised waste collection centres.

© 2007 - 2019 Datalogic S.p.A. and/or its affiliates • ALL RIGHTS RESERVED. • Without limiting the rights under copyright, no part of this documentation may be reproduced, stored in or introduced into a retrieval system, or transmitted in any form or by any means, or for any purpose, without the express written permission of Datalogic S.p.A. and/or its affiliates. Datalogic and the Datalogic logo are registered trademarks of Datalogic S.p.A. in many countries, including the U.S.A. and the E.U. All other trademarks and brands are property of their respective owners. Datalogic reserves the right to make modifications and improvements without prior notification.

SERIE SM3

Sbarramento polarizzato coassiale /
Emettitore-Ricevitore

MANUALE ISTRUZIONI

CONTROLLI

LED Giallo (luce ricevuta)

- Il LED acceso stabilmente indica: uscita ON per sensori funzionanti in modalità LUCE uscita OFF per sensori funzionanti in modalità BUIO.
- Il LED lampeggiante indica che il sensore sta lavorando con excess gain 1...1.5 (solo per SM3-PR-2-F00-xD)

LED Verde

- Il LED acceso stabilmente indica che il sensore è alimentato
- Il LED lampeggiante indica la presenza di un corto circuito sull'uscita

INSTALLAZIONE

L'installazione del sensore può essere effettuata grazie ai 2 fori passanti del corpo, tramite due viti (M2x16 o di maggiore lunghezza) con rondelle e dadi di serraggio

CONNESSIONI

Le connessioni sono configurate in conformità con la norma EN 60947-5-2.

SM3-PR-2-B00-xD / SM3-PR-2-F00-xD

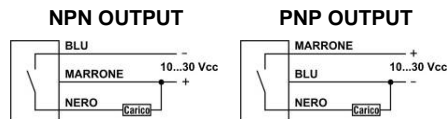

SM3-PR-2-G00-XX



Datalogic S.r.l.

Via S. Vitalino 13 - 40012 Calderara di Reno - Italy
Tel: +39 051 3147011 - Fax: +39 051 3147205 - www.datalogic.com

Link utili disponibili su www.datalogic.com: **Contatti, Termini e Condizioni, Supporto.**

Il periodo di garanzia per questo prodotto è di 36 mesi. Per maggiori dettagli vedere Condizioni Generali di Vendita su www.datalogic.com.

In base alle vigenti normative nazionali ed europee, Datalogic non è tenuta allo smaltimento del prodotto alla fine del ciclo di vita. Datalogic consiglia di smaltire gli apparecchi attenendosi alle normative nazionali vigenti in materia di smaltimento dei rifiuti o rivolgendosi agli appositi centri di conferimento.

© 2007 - 2017 Datalogic S.p.A. e/o le sue consociate • TUTTI I DIRITTI RISERVATI. • Senza con ciò limitare i diritti coperti dal copyright, nessuna parte della presente documentazione può essere riprodotta, memorizzata o introdotta in un sistema di recupero o trasmessa in qualsiasi forma o con qualsiasi mezzo, o per qualsiasi scopo, senza l'espreso consenso scritto di Datalogic S.p.A. e/o delle sue consociate. Datalogic e il logo Datalogic sono marchi registrati di Datalogic S.p.A. depositati in diversi paesi, tra cui U.S.A. e UE. Tutti gli altri marchi registrati e brand sono di proprietà dei rispettivi proprietari. Datalogic si riserva il diritto di apportare modifiche e/o miglioramenti senza preavviso.

826001982 Rev.E

DIMENSIONI D'INGOMBRO / DIMENSIONS

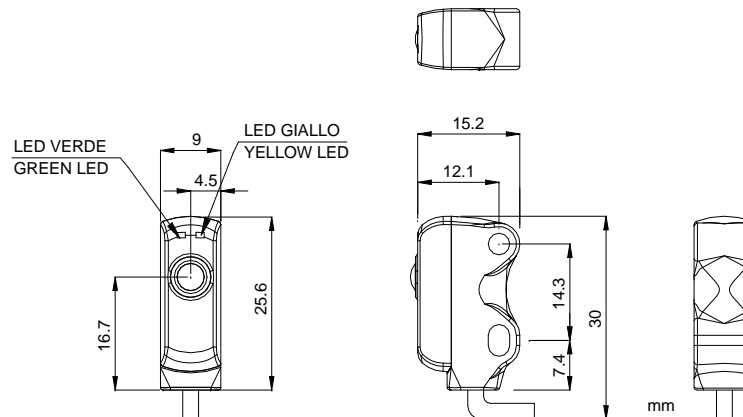

DATI TECNICI / TECHNICAL DATA

Tensione di alimentazione: <i>Power supply:</i>	10 ... 30 Vcc valori limite <i>limit values</i>
Assorbimento: <i>Current consumption:</i>	25 mA max. (escluso il carico) <i>(output current excluded)</i>
Uscite: <i>Output:</i>	PNP o NPN (protezione contro il cortocircuito) <i>PNP or NPN (short circuit protection)</i>
Modalità di funzionamento: <i>Operating mode</i>	LUCE (SM3-PR-2-B00-xL) / BUIO (SM3-PR-2-B00-xD e SM3-PR-2-F00-xD) <i>LIGHT (SM3-PR-2-B00-xL) / DARK (SM3-PR-2-B00-xD e SM3-PR-2-F00-xD)</i>
Corrente di uscita: <i>Output current</i>	50 mA max.
Tensione di saturazione dell'uscita: <i>Output saturation voltage:</i>	< 0.25 V a 10 mA; < 0.5 V a 50 mA <i>< 0.25 V at 10 mA; < 0.5 V at 50 mA</i>
Tempo di risposta: <i>Response time:</i>	1 ms
Frequenza di commutazione: <i>Switching frequency:</i>	500 Hz
Indicatori: <i>Indicators:</i>	LED GIALLO ON stabile = luce ricevuta Lampeggiante = Excess gain 1...1.5 (solo SM3-PR-2-F00-xD) LED VERDE ON stabile = Alimentazione attiva Lampeggiante = Corto circuito sull'uscita YELLOW LED ON steadily = light is sensed flashing = marginal excess gain 1...1.5 (only SM3-PR-2-F00-xD) GREEN LED ON steadily = power to sensor is ON flashing = output overload
Temperatura di funzionamento: <i>Operating temperature:</i>	-20 ... 55 °C
Temperatura di immagazzinamento: <i>Storage temperature:</i>	-25 ... 70 °C
Protezione elettrica: <i>Electrical shock protection:</i>	Classe 2 / Class 2
Distanza operativa (valori tipici): <i>Operating distance (typical values):</i>	0...30 cm su R7, 0...60 cm su R20 / 0...30 cm on R7, 0...60 cm on R20 (SM3-PR-2-B00-xx) 0...1.2 m (SM3-PR-2-FG00-xD)
Tipo di emissione: <i>Emission type:</i>	Rossa / Red 680 nm (SM3-PR-2-B00-xx) Rossa / Red 660 nm (SM3-PR-2-G00-xx)
Vibrazioni: <i>Vibration:</i>	ampiezza 0.5 mm, frequenza 10 ... 55 Hz, per ogni asse (EN60068-2-6) 0.5 mm amplitude, 10 ... 55 Hz frequency, for every axis (EN60068-2-6)
Resistenza agli urti: <i>Shock resistance:</i>	11 ms (30 G) 6 shock per ogni asse (EN60068-2-27) 11 ms (30 G) 6 shock for every axis (EN60068-2-27)
Materiale contenitore: <i>Housing material:</i>	ABS
Materiale lenti: <i>lenses material:</i>	PMMA (SM3-PR-2-FG00-xD) Vetro / Glass (SM3-PR-2-B00-xx)
Protezione meccanica: <i>Mechanical protection:</i>	IP67
Collegamenti: <i>Connections:</i>	cavo 2 m Ø 2.3 mm 3 fili / 2 m cable Ø 2.3 mm 3 wires (SM3-PR-2-B00-xL/SM3-PR-2-F00-xD) cavo 2 m Ø 2.3 mm 2 fili / 2 m cable Ø 2.3 mm 2 wires (SM3-PR-2-G00-xx)
Peso / Weight:	17 g.

SM3 SERIES

Coaxial Polarised Retroreflex /
Through beam

INSTRUCTION MANUAL

CONTROLS

Yellow LED (LIGHT sensed)

- LED ON steadily means: output ON with sensors working in LIGHT mode output OFF with sensors working in DARK mode
- LED flashing means marginal excess gain 1...1.5 (only for SM3-PR-2-F00-xD)

Green LED

- LED ON steadily means power to sensor is ON.
- LED flashing means output overload.

INSTALLATION

The sensor can be positioned by means of the two housing's holes using two screws (M2x16 or longer) with nuts and washers.

CONNECTIONS

The connections are compliant to the EN 60947-5-2 standard.

SM3-PR-2-B00-xD / SM3-PR-2-F00-xD

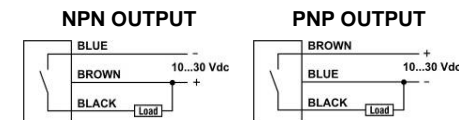

SM3-PR-2-G00-XX

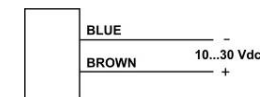

Datalogic S.r.l.

Via S. Vitalino 13 - 40012 Calderara di Reno - Italy
Tel: +39 051 3147011 - Fax: +39 051 3147205 - www.datalogic.com

Helpful links at www.datalogic.com: **Contact Us, Terms and Conditions, Support.**

The warranty period for this product is 36 months. See General Terms and Conditions of Sales for further details.

Under current Italian and European laws, Datalogic is not obliged to take care of product disposal at the end of its life. Datalogic recommends disposing of the product in compliance with local laws or contacting authorised waste collection centres.

© 2007 - 2017 Datalogic S.p.A. and/or its affiliates • ALL RIGHTS RESERVED. • Without limiting the rights under copyright, no part of this documentation may be reproduced, stored in or introduced into a retrieval system, or transmitted in any form or by any means, or for any purpose, without the express written permission of Datalogic S.p.A. and/or its affiliates. Datalogic and the Datalogic logo are registered trademarks of Datalogic S.p.A. in many countries, including the U.S.A. and the E.U. All other trademarks and brands are property of their respective owners. Datalogic reserves the right to make modifications and improvements without prior notification.

826001982 Rev.E

SM3-SERIE

koaxiale Reflexlichtschranke polarisiert /
Einweglichtschranke

BEDIENUNGSANLEITUNG

ANZEIGE- UND BEDIENELEMENTE

gelbe LED (Licht empfangen)

- Die ständig aufleuchtende LED signalisiert: Ausgang ON bei hellerschaltenden Sensoren
Ausgang OFF bei dunkelschaltenden Sensoren.
- Die blinkende LED signalisiert, dass der Sensor mit 1...1.5 Funktionsreserve arbeitet (nur bei SM3-PR-2-F00-xD)

grüne LED

- Die ständig aufleuchtende LED signalisiert Betriebsbereitschaft.
- Die blinkende LED signalisiert Ausgang überlastet.

INSTALLATION

Die Installation des Sensors erfolgt mit Hilfe von zwei Schrauben (M2X16 oder länger) mit Muttern und Unterlegscheiben über zwei Bohrungen am Gehäuse.

ANSCHLUSS

Der Anschluss entspricht der Norm EN 60947-5-2.

SM3-PR-2-B00-xD / SM3-PR-2-F00-xD

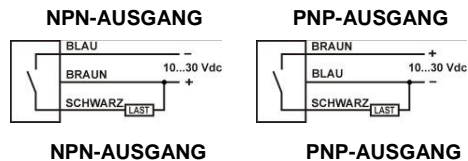

SM3-PR-2-G00-XX



Datalogic S.r.l.

Via S. Vitalino 13 - 40012 Calderara di Reno - Italy
Tel: +39 051 3147011 - Fax: +39 051 3147205 - www.datalogic.com

Nützliche Links unter www.datalogic.com: **Kontakt, Terms and Conditions, Support.**

Die Gewährleistungsfrist für dieses Produkt beträgt 36 Monate. Für weitere Informationen siehe allgemeine Verkaufsbedingungen unter www.datalogic.com.

In Abhängigkeit der nationalen und europäischen Richtlinien ist Datalogic nicht zur Entsorgung des Produkts am Ende seiner Standzeit verpflichtet. Datalogic empfiehlt die Entsorgung der Geräte unter Einhaltung der nationalen Vorschriften bezüglich der Abfallentsorgung vorzunehmen oder sich diesbezüglich an die zuständigen Sammelanlagen zu wenden.

© 2007 - 2017 Datalogic S.p.A. und/oder die Tochtergesellschaften • ALLE RECHTE VORBEHALTEN. • Ohne die im Urheberrecht festgelegten Rechte einzuschränken, darf kein Teil dieses Dokuments ohne die ausdrückliche schriftliche Erlaubnis von Datalogic S.p.A. und/oder den Tochtergesellschaften vervielfältigt, in einem Datenabfragesystem gespeichert oder eingeführt oder in irgendeiner Form, mittels irgendwelcher Methode oder für irgendwelchen Zweck übermittelt werden. Datalogic und das Logo von Datalogic sind eingetragene Handelsmarken von Datalogic S.p.A. in vielen Ländern, einschließlich den USA und der EU. Alle sonstigen, angegebenen Marken und Produktbezeichnungen gehören den jeweiligen Eigentümern. Datalogic behält sich das Recht vor Modifikationen und Verbesserungen am Produkt jederzeit einzubringen.

ABMESSUNGEN / DIMENSIONS

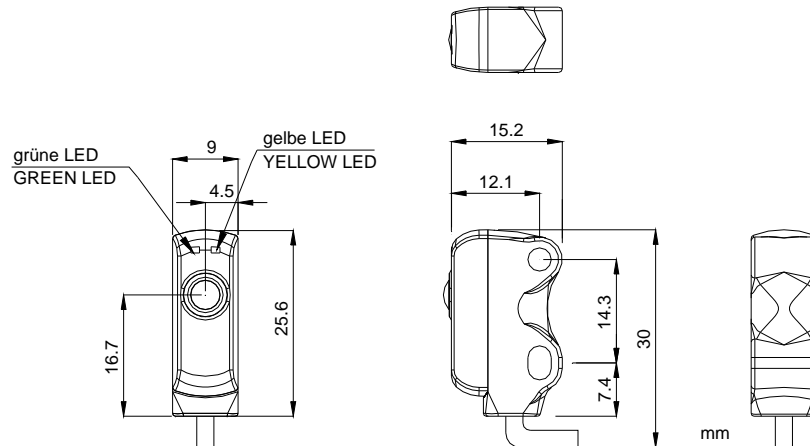

TECHNISCHE DATEN / TECHNICAL DATA

Betriebsspannung/Power supply:	10 ... 30 Vdc Grenzwerte/limit values	
Stromaufnahme: Current consumption:	25 mA max. (ohne Last) (output current excluded)	
Ausgänge: Output:	PNP oder NPN (kurzschlussfest) PNP or NPN (short circuit protection)	
Schaltungsart: Operating mode	HELL (SM3-PR-2-B00-xL) / DUNKEL (SM3-PR-2-B00-xD und SM3-PR-2-F00-xD) LIGHT (SM3-PR-2-B00-xL) / DARK (SM3-PR-2-B00-xD and SM3-PR-2-F00-xD)	
Ausgangsstrom: Output current:	50 mA max.	
Sättigungsspannung: Output saturation voltage:	< 0.25 V bei 10 mA; < 0.5 V bei 50 mA < 0.25 V at 10 mA; < 0.5 V at 50 mA	
Ansprechzeit: Response time:	1 ms	
Schaltfrequenz: Switching frequency:	500 Hz	
Funktionsanzeige:	Gelbe LED	ständig ON = Licht empfangen blinkend = Funktionsreserve 1...1.5 (nur bei SM3-PR-2-F00-xD)
Indicators:	grüne LED	ständig ON = betriebsbereit blinkend = Ausgang überlastet
	YELLOW LED	ON steadily= light is sensed flashing= marginal excess gain 1...1.5 (only SM3-PR-2-F00-xD)
	GREEN LED	ON steadily= power to sensor is ON flashing= output overload
Betriebstemperatur: Operating temperature:	-20...55 °C	
Lagertemperatur: Storage temperature:	-25...70 °C	
Schutzklasse: Electrical shock protection:	Klasse 2 / Class 2	
Reichweite (typ. Werte): Operating distance (typical values):	0...30 cm bei R7, 0...60 cm bei R20 / 0...30 cm on R7, 0...60 cm on R20 (SM3-PR-2-B00-xx)	
Sender, Wellenlänge: Emission type:	0...1.2 m (SM3-PR-2-FG00-xD) rot / Red 680 nm (SM3-PR-2-B00-xx) rot / Red 660 nm (SM3-PR-2-G00-xx)	
Vibration:	Amplitude 0.5 mm, Frequenz 10 ... 55 Hz, pro Achse (EN60068-2-6)	
Vibration:	.5 mm amplitude, 10 ... 55 Hz frequency, for every axis (EN60068-2-6)	
Schockbeständigkeit: Shock resistance:	11 ms (30 G) 6 Schocks pro Achse (EN60068-2-27) 11 ms (30 G) 6 shock for every axis (EN60068-2-27)	
Gehäusematerial: Housing material:	ABS	
Linse(n)material: lenses material:	PMMA (SM3-PR-2-FG00-xD) Glas / Glass (SM3-PR-2-B00-xx)	
Schutzart: Mechanical protection:	IP67	
Anschluss: Connections:	2 m Kabel, Ø 2.3 mm, 3 Adern/2 m cable Ø 2.3 mm 3 wires (SM3-PR-2-B00-xL/SM3-PR-2-F00-xD)	
Gewicht/ Weight:	2 m Kabel, Ø 2.3 mm, 3 Adern / 2 m cable Ø 2.3 mm 2 wires (SM3-PR-2-G00-xx) 17 g	

SM3 SERIES

Coaxial Polarised Retroreflex /
Through beam

INSTRUCTION MANUAL

CONTROLS

Yellow LED (LIGHT sensed)

- LED ON steadily means: output ON with sensors working in LIGHT mode
output OFF with sensors working in DARK mode
- LED flashing means marginal excess gain 1...1.5 (only for SM3-PR-2-F00-xD)

Green LED

- LED ON steadily means power to sensor is ON.
- LED flashing means output overload.

INSTALLATION

The sensor can be positioned by means of the two housing's holes using two screws (M2x16 or longer) with nuts and washers.

CONNECTIONS

The connections are compliant to the EN 60947-5-2 standard.

SM3-PR-2-B00-xD / SM3-PR-2-F00-xD

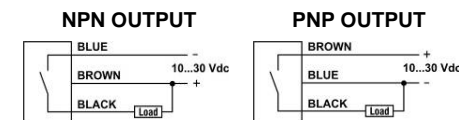

SM3-PR-2-G00-XX

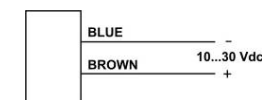

Datalogic S.r.l.

Via S. Vitalino 13 - 40012 Calderara di Reno - Italy
Tel: +39 051 3147011 - Fax: +39 051 3147205 - www.datalogic.com

Helpful links at www.datalogic.com: **Contact Us, Terms and Conditions, Support.**

The warranty period for this product is 36 months. See General Terms and Conditions of Sales for further details.

Under current Italian and European laws, Datalogic is not obliged to take care of product disposal at the end of its life. Datalogic recommends disposing of the product in compliance with local laws or contacting authorised waste collection centres.

© 2007 - 2017 Datalogic S.p.A. and/or its affiliates • ALL RIGHTS RESERVED. • Without limiting the rights under copyright, no part of this documentation may be reproduced, stored in or introduced into a retrieval system, or transmitted in any form or by any means, or for any purpose, without the express written permission of Datalogic S.p.A. and/or its affiliates. Datalogic and the Datalogic logo are registered trademarks of Datalogic S.p.A. in many countries, including the U.S.A. and the E.U. All other trademarks and brands are property of their respective owners. Datalogic reserves the right to make modifications and improvements without prior notification.