

SE-SR2



Safety relays



22 224-07

Introduction	3
Validity of documentation	3
Using the documentation	3
Definition of symbols	3
Safety	4
Intended use	4
Safety regulations	4
Safety assessment	4
Use of qualified personnel	5
Warranty and liability	5
Disposal	5
For your safety	5
Unit features	6
Safety features	6
Block diagram/terminal configuration	6
Function Description	7
Operating modes	7
Timing diagram	7
Installation	8
Wiring	8
Preparing for operation	9
Operation	10
Status indicators	10
Faults – Interference	11
Dimensions in mm	11
Technical details	11
Safety characteristic data	15
Supplementary data	16
Service life graph	16
Remove plug-in terminals	18
Order reference	18
EC declaration of conformity	19

Introduction

Validity of documentation

This documentation is valid for the product SE-SR2. It is valid until new documentation is published.

This operating manual explains the function and operation, describes the installation and provides guidelines on how to connect the product.

Using the documentation

This document is intended for instruction. Only install and commission the product if you have read and understood this document. The document should be retained for future reference.

Definition of symbols

Information that is particularly important is identified as follows:



DANGER!

This warning must be heeded! It warns of a hazardous situation that poses an immediate threat of serious injury and death and indicates preventive measures that can be taken.



WARNING!

This warning must be heeded! It warns of a hazardous situation that could lead to serious injury and death and indicates preventive measures that can be taken.



CAUTION!

This refers to a hazard that can lead to a less serious or minor injury plus material damage, and also provides information on preventive measures that can be taken.



NOTICE

This describes a situation in which the product or devices could be damaged and also provides information on preventive measures that can be taken. It also highlights areas within the text that are of particular importance.



INFORMATION

This gives advice on applications and provides information on special features.

Safety

Intended use

The safety relay SE-SR2 provides a safety-related interruption of a safety circuit.

The safety relay meets the requirements of EN 60947-5-1 and EN 60204 and may be used in applications with light guards.

The following is deemed improper use in particular

- ▶ Any component, technical or electrical modification to the product,
- ▶ Use of the product outside the areas described in this manual,
- ▶ Use of the product outside the technical details (see [Technical details](#)  11]).



NOTICE

EMC-compliant electrical installation

The product is designed for use in an industrial environment. The product may cause interference if installed in other environments. If installed in other environments, measures should be taken to comply with the applicable standards and directives for the respective installation site with regard to interference.

Safety regulations

Safety assessment

Before using a device, a safety assessment in accordance with the Machinery Directive is required.

The product as an individual component fulfils the functional safety requirements in accordance with EN ISO 13849 and EN 62061. However, this does not guarantee the functional safety of the overall plant/machine. To achieve the relevant safety level of the overall plant/machine's required safety functions, each safety function needs to be considered separately.

Use of qualified personnel

The products may only be assembled, installed, programmed, commissioned, operated, maintained and decommissioned by persons who are competent to do so.

A competent person is a qualified and knowledgeable person who, because of their training, experience and current professional activity, has the specialist knowledge required. To be able to inspect, assess and operate devices, systems and machines, the person has to be informed of the state of the art and the applicable national, European and international laws, directives and standards.

It is the company's responsibility only to employ personnel who

- ▶ Are familiar with the basic regulations concerning health and safety / accident prevention,
- ▶ Have read and understood the information provided in the section entitled Safety
- ▶ Have a good knowledge of the generic and specialist standards applicable to the specific application.

Warranty and liability

All claims to warranty and liability will be rendered invalid if

- ▶ The product was used contrary to the purpose for which it is intended,
- ▶ Damage can be attributed to not having followed the guidelines in the manual,
- ▶ Operating personnel are not suitably qualified,
- ▶ Any type of modification has been made (e.g. exchanging components on the PCB boards, soldering work etc.).

Disposal

- ▶ In safety-related applications, please comply with the mission time T_M in the safety-related characteristic data.
- ▶ When decommissioning, please comply with local regulations regarding the disposal of electronic devices (e.g. Electrical and Electronic Equipment Act).

For your safety

The unit meets all the necessary conditions for safe operation. However, please note the following:

- ▶ Note for overvoltage category III: If voltages higher than low voltage (>50 VAC or >120 VDC) are present on the unit, connected control elements and sensors must have a rated insulation voltage of at least 250 V.

Unit features

- ▶ Positive-guided relay outputs:
 - 3 safety contacts (N/O), instantaneous
 - 1 auxiliary contact (N/C), instantaneous
- ▶ Connection options for:
 - Start button
 - Light grids
- ▶ LED display for:
 - Supply voltage
 - Switch status of the safety contacts
- ▶ No galvanic isolation between U_b and input circuit
- ▶ Plug-in connection terminals

Safety features

The safety relay meets the following safety requirements:

- ▶ The circuit is redundant with built-in self-monitoring.
- ▶ The safety function remains effective in the case of a component failure.
- ▶ The correct opening and closing of the safety function relays is tested automatically in each on-off cycle.

Block diagram/terminal configuration

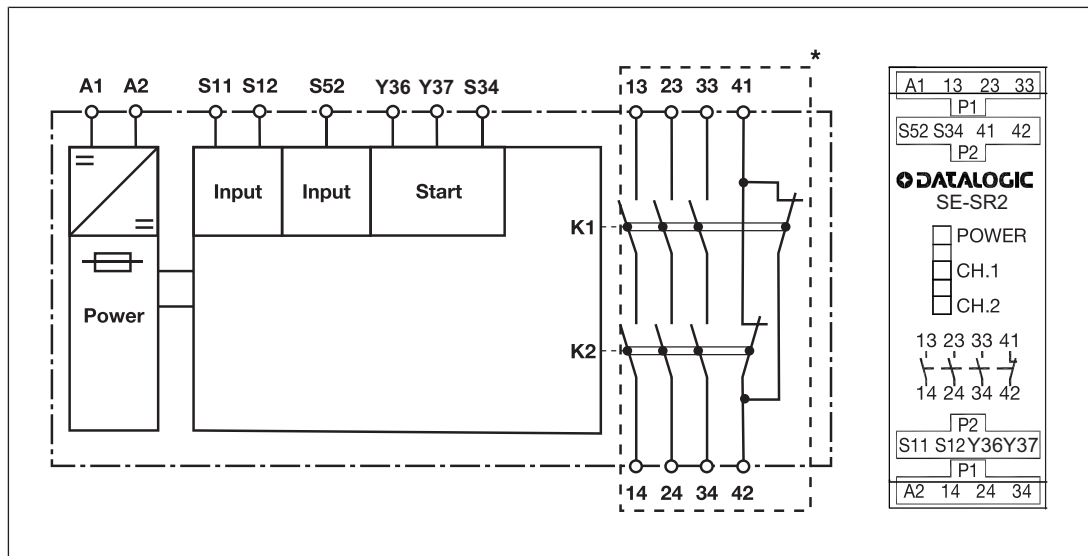

*Insulation between the non-marked area and the relay contacts: Basic insulation (over-voltage category III), Protective separation (overvoltage category II)

Function Description

The relay SE-SR2 provides a safety-oriented interruption of a safety circuit. When operating voltage is supplied the "POWER" LED will light up. The unit is ready for operation when the start circuit S12-S34 is closed.

- ▶ Input circuit is closed (e.g. light grid not interrupted):
 - The LEDs "CH.1" and "CH.2" are lit.
 - Safety contacts 13-14, 23-24 and 33-34 are closed, auxiliary contact 41-42 is open. The unit is active.
- ▶ Input circuit is opened (e.g. light grid interrupted):
 - The LEDs "CH.1" and "CH.2" go out.
 - Safety contacts 13-14, 23-24 and 33-34 are opened redundantly, auxiliary contact 41-42 is closed.

Operating modes

- ▶ Dual-channel operation without detection of shorts across contacts: Redundant input circuit, detects SE-SR2
 - earth faults in the start and input circuit,
 - short circuits in the input circuit.
- ▶ Automatic start: Unit is active once the input circuit has been closed.
- ▶ Manual start without control: Unit is active once the input circuit and the start circuit are closed.
- ▶ Manual start with control: Unit is active once the input circuit is closed and once the start circuit is closed after the waiting period has elapsed (see [Technical details](#)  11).
- ▶ Increase in the number of available contacts by connecting contact expansion modules or external contactors/relays.

Timing diagram

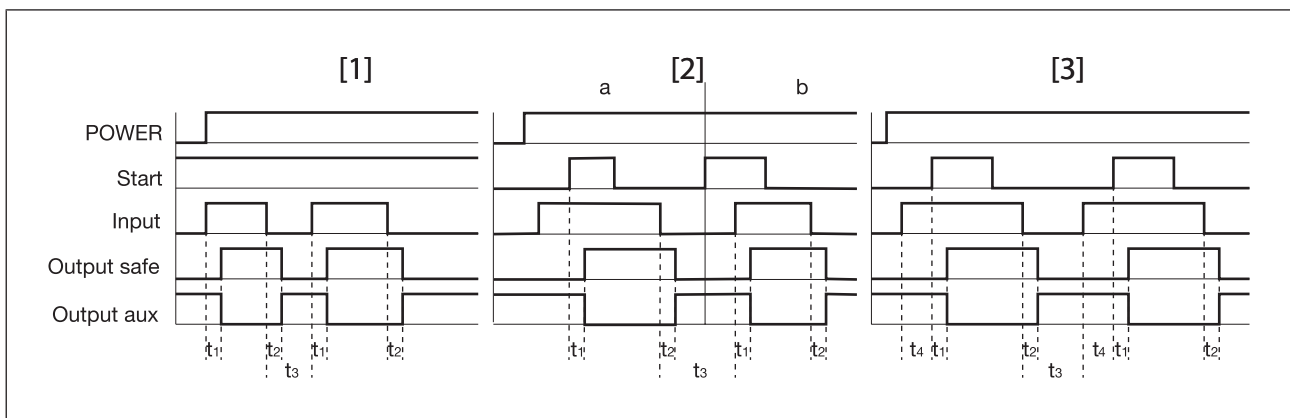

Legend

- ▶ Power: Supply voltage
- ▶ Start: Start circuit
- ▶ Input: Input circuit
- ▶ Output safe: Safety contacts

- ▶ Output aux: Auxiliary contact
- ▶ [1]: Automatic start
- ▶ [2]: Manual start without control
- ▶ [3]: Manual start with control
- ▶ a: Input circuit closes before start circuit
- ▶ b: Start circuit closes before input circuit
- ▶ t_1 : Switch-on delay
- ▶ t_2 : Delay-on de-energisation
- ▶ t_3 : Recovery time
- ▶ t_4 : Waiting period with a monitored start

Installation

- ▶ The unit should be installed in a control cabinet with a protection type of at least IP54.
- ▶ Use the notch on the rear of the unit to attach it to a DIN rail (35 mm).
- ▶ When installed vertically: Secure the unit by using a fixing element (e.g. retaining bracket or end angle).

Wiring

Please note:

- ▶ Information given in the "[Technical details \[11\]](#)" must be followed.
- ▶ Outputs 13-14, 23-24, 33-34 are safety contacts; output 41-42 is an auxiliary contact (e.g. for display).
- ▶ Auxiliary contact 41-42 should **not** be used for safety circuits!
- ▶ To prevent contact welding, a fuse should be connected before the output contacts (see [Technical details \[11\]](#)).
- ▶ Calculation of the max. cable length l_{\max} in the input circuit:

$$l_{\max} = \frac{R_{l_{\max}}}{R_l / \text{km}}$$

$R_{l_{\max}}$ = max. overall cable resistance (see [Technical details \[11\]](#))

R_l / km = cable resistance/km

- ▶ Use copper wiring with a temperature stability of 60/75 °C.
- ▶ To prevent EMC interferences (particularly common-mode interferences) the measures described in EN 60204-1 must be executed. This includes the separate routing of cables of the control circuits (input, start and feedback loop) from other cables for energy transmission or the shielding of cables, for example.
- ▶ Do not switch low currents using contacts that have been used previously with high currents.
- ▶ Adequate protection must be provided on all output contacts with capacitive and inductive loads.
- ▶ The power supply must comply with the regulations for extra low voltages with protective electrical separation (SELV, PELV) in accordance with VDE 0100, Part 410.

Preparing for operation

Supply voltage	AC	DC
Input circuit	Single-channel	Dual-channel
Light grid, detection of shorts across contacts via ESPE		



NOTICE

Operation with a light grid

It must not be possible to switch off the supply voltage for the SE-SR2 separately from the supply voltage for the light grid.

Start circuit	Single-channel	Dual-channel
Automatic start		
Manual start without control		
Manual start with control		



NOTICE

In the event of an automatic start or manual start with bridged start contact (fault):

The unit starts up automatically when the safeguard is reset, e.g. when the E-STOP pushbutton is released. Use external circuit measures to prevent an unexpected restart.

Feedback loop	Automatic start	Manual start without control, Manual start with control
Contacts from external contactors		

Legend

- ▶ S3: Start button



INFORMATION

With automatic start and manual start without control, Y36 and Y37 must not be bridged.

Operation



NOTICE

The safety function should be checked after initial commissioning and each time the plant/machine is changed. The safety functions may only be checked by qualified personnel.

When the relay outputs are switched on, the mechanical contact on the relay cannot be tested automatically. Depending on the operational environment, measures to detect the non-opening of switching elements may be required under some circumstances.

When the product is used in accordance with the European Machinery Directive, a check must be carried out to ensure that the safety contacts on the relay outputs open correctly. Start the device again or open the safety contacts (switch off output), so that the internal diagnostics can check the correct opening of the safety contacts

- ▶ for SIL CL 3/PL e at least 1x per month
- ▶ for SIL CL 2/PL d at least 1x per year

Status indicators

LEDs indicate the status and errors during operation:



LED on



POWER

Supply voltage is present.



CH.1

Safety contacts of channel 1 are closed.



CH.2

Safety contacts of channel 2 are closed.

Faults – Interference

- ▶ Earth fault: The supply voltage fails and the safety contacts open. Once the cause of the respective fault has been rectified and the supply voltage is switched off for approx. 1 minute, the unit is ready for operation again.
- ▶ Contact malfunctions: If the contacts have welded, reactivation will not be possible after the input circuit has opened.
- ▶ LED "POWER" does not light: Short circuit or no supply voltage.

Dimensions in mm

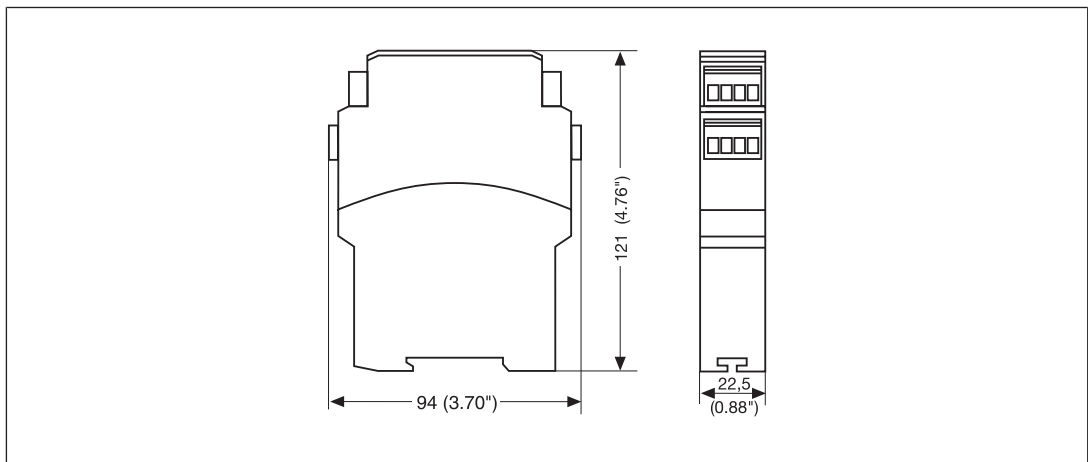

Technical details

General	
Certifications	CE, TÜV, cULus Listed
Electrical data	
Supply voltage	
Voltage	24 V
Kind	DC
Voltage tolerance	-15 %/+10 %
Output of external power supply (DC)	2 W
Residual ripple DC	160 %
Duty cycle	100 %
Max. inrush current impulse	
Current pulse, A1	1,7 A
Pulse duration, A1	3,3 ms
Inputs	
Number	2

Inputs

Voltage at

Input circuit DC	24 V
Start circuit DC	24 V
Feedback loop DC	24 V

Current at

Input circuit DC	30 mA
Start circuit DC	60 mA
Feedback loop DC	60 mA

Max. overall cable resistance R_{lmax}

Dual-channel without detection of shorts across contacts at UB DC	80 Ohm
---	---------------

Relay outputs

Number of output contacts

Safety contacts (N/O), instantaneous	3
Auxiliary contacts (N/C)	1

Max. short circuit current I_K

1 kA

Utilisation category

In accordance with the standard	EN 60947-4-1
---------------------------------	---------------------

Utilisation category of safety contacts

AC1 at	240 V
Min. current	0,01 A
Max. current	6 A
Max. power	1500 VA
DC1 at	24 V
Min. current	0,01 A
Max. current	6 A
Max. power	150 W

Utilisation category of auxiliary contacts

AC1 at	240 V
Min. current	0,01 A
Max. current	6 A
Max. power	1500 VA
DC1 at	24 V
Min. current	0,01 A
Max. current	6 A
Max. power	150 W

Utilisation category

In accordance with the standard	EN 60947-5-1
---------------------------------	---------------------

Utilisation category of safety contacts

AC15 at	230 V
Max. current	3 A
DC13 (6 cycles/min) at	24 V
Max. current	4 A

Relay outputs

Utilisation category of auxiliary contacts

AC15 at	230 V
Max. current	3 A
DC13 (6 cycles/min) at	24 V
Max. current	4 A

Utilisation category in accordance with UL

Voltage	250 V AC G.U. (same polarity)
With current	6 A
Voltage	24 V DC G. U.
With current	6 A
Pilot Duty	B300, R300

External contact fuse protection, safety contacts

In accordance with the standard	EN 60947-5-1
Max. melting integral	66 A²s
Blow-out fuse, quick	6 A
Blow-out fuse, slow	4 A
Blow-out fuse, gG	6 A
Circuit breaker 24V AC/DC, characteristic B/C	4 A

External contact fuse protection, auxiliary contacts

Max. melting integral	66 A²s
Blow-out fuse, quick	6 A
Blow-out fuse, slow	4 A
Blow-out fuse, gG	6 A
Circuit breaker 24 V AC/DC, characteristic B/C	4 A

Contact material **AgSnO₂ + 0,2 µm Au**

Conventional thermal current while loading several contacts

I_{th} per contact at UB DC; AC1: 240 V, DC1: 24 V

Conv. therm. current with 1 contact	6 A
Conv. therm. current with 2 contacts	6 A
Conv. therm. current with 3 contacts	4,5 A

Times

Switch-on delay

With automatic start typ.	200 ms
With automatic start max.	400 ms
With manual start typ.	100 ms
With manual start max.	400 ms
With monitored start typ.	30 ms
With monitored start max.	50 ms

Delay-on de-energisation

With E-STOP typ.	10 ms
With E-STOP max.	20 ms
With power failure typ.	70 ms
With power failure max.	120 ms

Times

Recovery time at max. switching frequency 1/s	
After E-STOP	50 ms
After power failure	150 ms
Waiting period with a monitored start	200 ms
Min. start pulse duration with a monitored start	30 ms
Supply interruption before de-energisation	20 ms
Simultaneity, channel 1 and 2 max.	∞

Environmental data

Climatic suitability	EN 60068-2-78
Ambient temperature	
Temperature range	-10 - 55 °C
Storage temperature	
Temperature range	-40 - 85 °C
Climatic suitability	
Humidity	93 % r. h. at 40 °C
Condensation during operation	Not permitted
EMC	EN 60947-5-1, EN 61000-6-2, EN 61326-3-1
Vibration	
In accordance with the standard	EN 60068-2-6
Frequency	10 - 55 Hz
Amplitude	0,35 mm
Airgap creepage	
In accordance with the standard	EN 60947-1
Overvoltage category	III / II
Pollution degree	2
Rated insulation voltage	250 V
Rated impulse withstand voltage	4 kV
Protection type	
Housing	IP40
Terminals	IP20
Mounting area (e.g. control cabinet)	IP54

Mechanical data

Mounting position	Any
Mechanical life	10,000,000 cycles
Material	
Bottom	PPO UL 94 V0
Front	ABS UL 94 V0
Top	PPO UL 94 V0
Connection type	Screw terminal
Mounting type	plug-in

Mechanical data

Conductor cross section with screw terminals

1 core flexible	0,25 - 2,5 mm², 24 - 12 AWG
2 core with the same cross section, flexible with crimp connectors, no plastic sleeve	0,25 - 1 mm², 24 - 16 AWG
2 core with the same cross section, flexible without crimp connectors or with TWIN crimp connectors	0,2 - 1,5 mm², 24 - 16 AWG

Torque setting with screw terminals **0,5 Nm**

Stripping length with screw terminals **8 mm**

Dimensions

Height	94 mm
Width	22,5 mm
Depth	121 mm

Weight **180 g**

Where standards are undated, the 2020-07 latest editions shall apply.

Safety characteristic data



NOTICE

You must comply with the safety characteristic data in order to achieve the required safety level for your plant/machine.

Operating mode	EN ISO 13849-1: 2015	EN ISO 13849-1: 2015	EN 62061 SIL CL	EN 62061 PFH _D [1/h]	IEC 61511 SIL	IEC 61511 PFD	EN ISO 13849-1: 2015
	PL	Category					T _M [year]
–	PL e	Cat. 4	SIL CL 3	2,31E-09	SIL 3	2,03E-06	20

Explanatory notes for the safety-related characteristic data:

- ▶ The SIL CL value in accordance with EN 62061 corresponds to the SIL value in accordance with EN 61508.
- ▶ T_M is the maximum mission time in accordance with EN ISO 13849-1. The value also applies as the retest interval in accordance with EN 61508-6 and IEC 61511 and as the proof test interval and mission time in accordance with EN 62061.

All the units used within a safety function must be considered when calculating the safety characteristic data.



INFORMATION

A safety function's SIL/PL values are **not** identical to the SIL/PL values of the units that are used and may be different. We recommend that you use the PAScal software tool to calculate the safety function's SIL/PL values.

Supplementary data



CAUTION!

It is essential to consider the relay's service life graphs. The relay outputs' safety-related characteristic data is only valid if the values in the service life graphs are met.

The PFH value depends on the switch frequency and the load of the relay output. If the service life graphs are not accessible, the stated PFH value can be used irrespective of the switch frequency and the load, as the PFH value already considers the relay's B10d value as well as the failure rates of the other components.

Service life graph

The service life graphs indicate the number of cycles from which failures due to wear must be expected. The wear is mainly caused by the electrical load; the mechanical load is negligible.

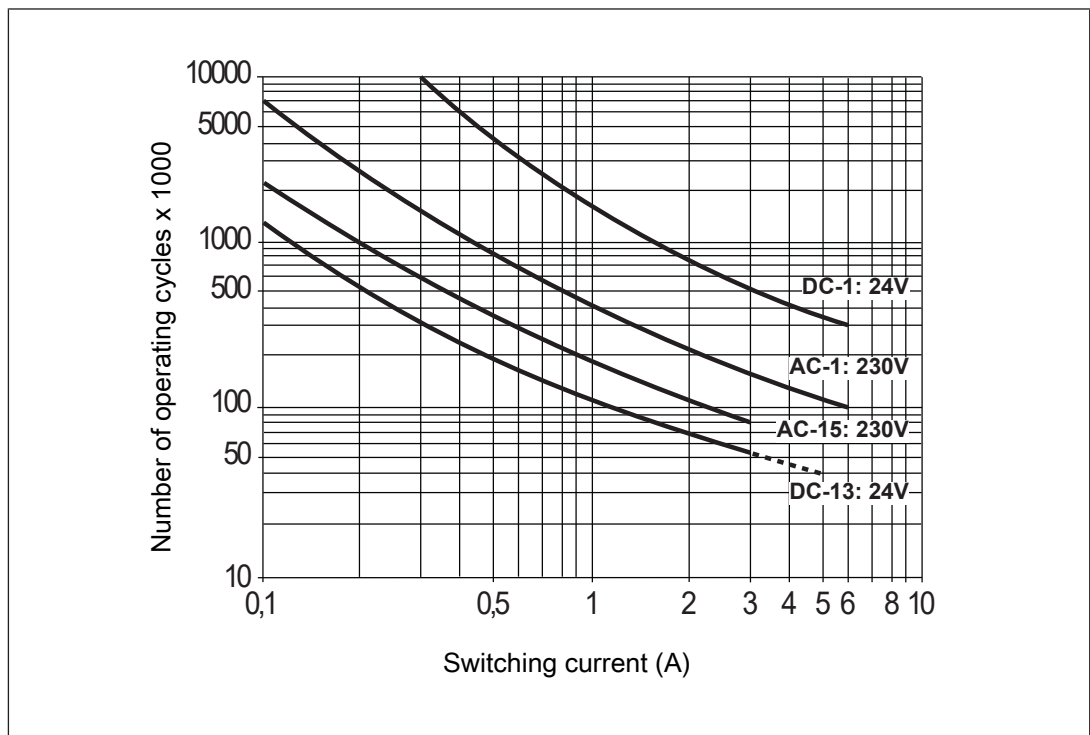

Fig.: Service life graphs at 24 VDC and 230 VAC

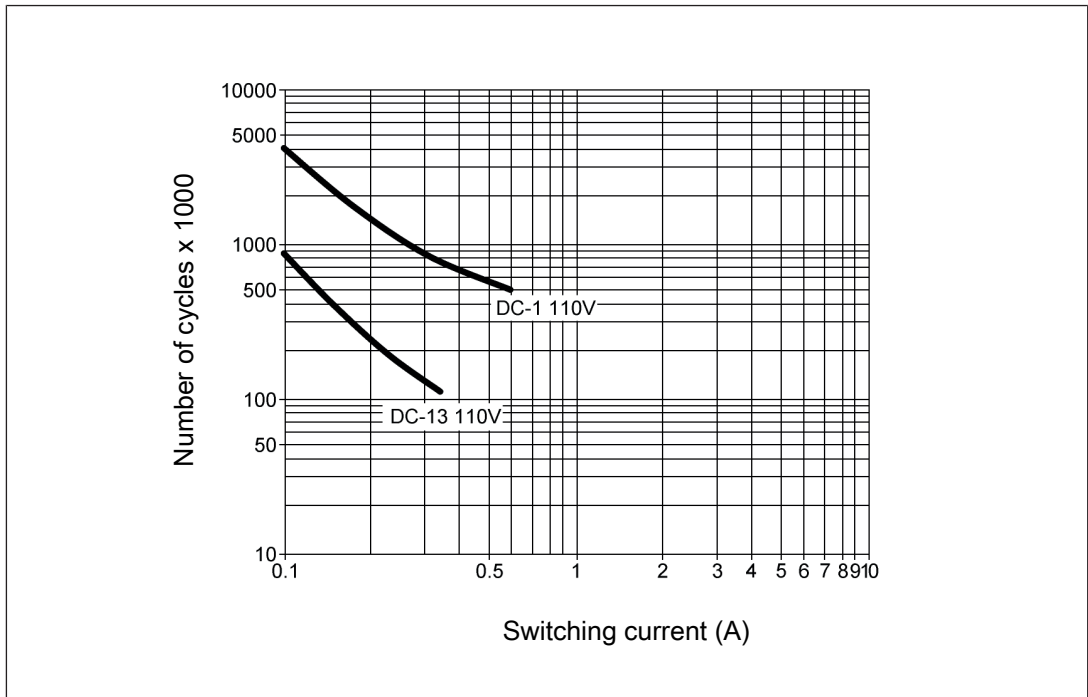

Fig.: Service life graphs at 110 VDC

Example

- ▶ Inductive load: 0.2 A
- ▶ Utilisation category: AC15
- ▶ Contact service life: 1 000 000 cycles

Provided the application to be implemented requires fewer than 1 000 000 cycles, the PFH value (see [Technical details \[11\]](#)) can be used in the calculation.

To increase the service life, sufficient spark suppression must be provided on all relay contacts. With capacitive loads, any power surges that occur must be noted. With DC contactors, use flywheel diodes for spark suppression.

Remove plug-in terminals

Procedure: Insert the screwdriver into the housing recess behind the terminal and lever the terminal out.

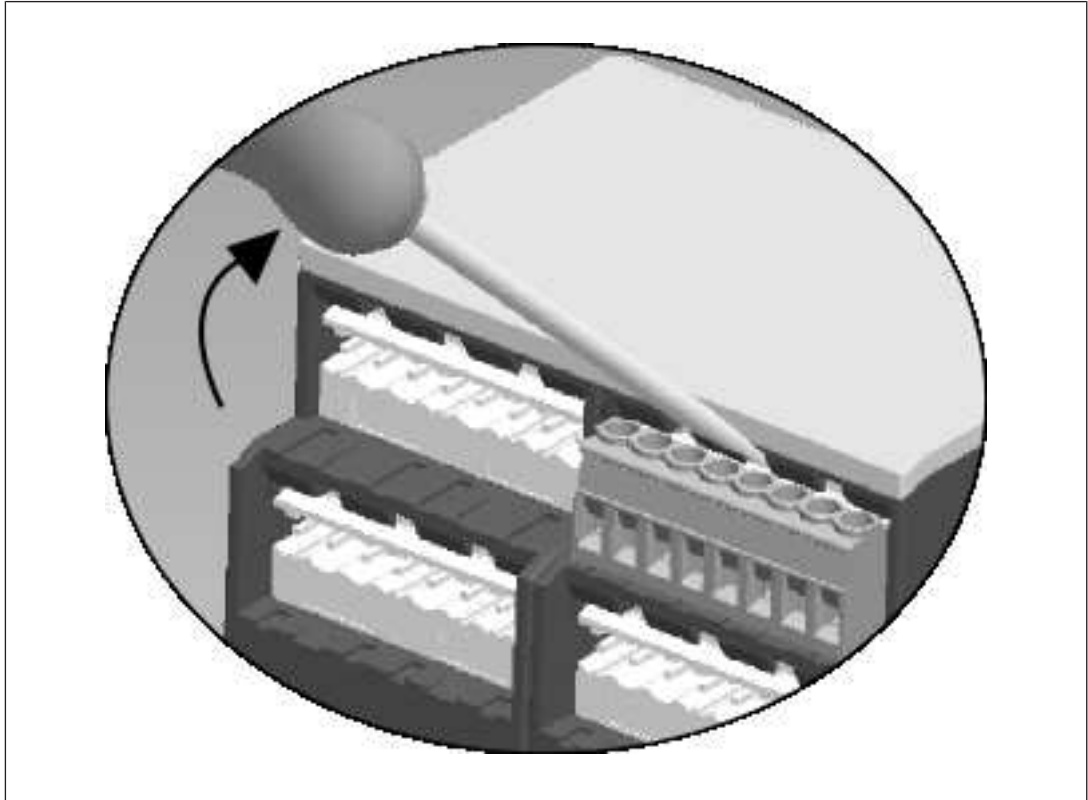

Do **not** remove the terminals by pulling the cables!



Order reference

Product type	Features	Connection type	Order No.
SE-SR2	24 VDC	Screw terminals	95ACC6170

EC declaration of conformity

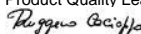
	<p>EU DECLARATION OF CONFORMITY UE DICHIARAZIONE DI CONFORMITA' UE DECLARACIÓN DE CONFORMIDAD UE DÉCLARATION DE CONFORMITÉ EU KONFORMITÄTserKLÄRUNG EU KONFORMITEITSVERKLARING EU FÖRSÄKRAN OM ÖVERENSSTÄMMELSE</p>	<p>EC-326_2 Pag. 1 of 1</p> 
<p>Apparatus / Apparato / Aparato / Appareil / Gerätetyp / Apparaatmodel / Apparatmodell</p>		
<p align="center">SE-SR2; EMERGENCY - STOP SAFETY DEVICE</p>		
<p>and all its models / e tutti i suoi modelli / y todos sus modelos / et tous ses modèles / und seine modelle / en al haar modellen / och alla sina modeller</p>		
<p>Manufacturer / Produttore / Fabricante / Fabricant / Hersteller / Fabrikant / Tillverkaren</p> <p align="center">Datalogic S.r.l. Via S.Vitalino 13 - 40012 Calderara di Reno - Bologna ITALY</p>		
<p>This declaration of conformity is issued under the sole responsibility of the manufacturer / La presente dichiarazione di conformità è rilasciata sotto la responsabilità esclusiva del fabbricante / La presente declaración de conformidad se expide bajo la exclusiva responsabilidad del fabricante / La présente déclaration de conformité est établie sous la seule responsabilité du fabricant / Die alleinige Verantwortung für die Ausstellung dieser onformitätserklärung trägt der Hersteller / Deze conformiteitsverklaring wordt verstrekt onder volledige verantwoordelijkheid van de fabrikant / Denna försäkran om överensstämmelse utfärdas på tillverkarens eget ansvar.</p>		
<p>The object of the declaration described above is in conformity with the relevant Union harmonization legislation: / L'oggetto della dichiarazione di cui sopra è conforme alla pertinente normativa di armonizzazione dell'Unione: / El objeto de la declaración descrita anteriormente es conforme con la legislación de armonización pertinente de la Unión: / L'objet de la déclaration décrit ci-dessus est conforme à la législation d'harmonisation de l'Union applicable: / Der oben beschriebene Gegenstand der Erklärung erfüllt die einschlägigen Harmonisierungsrechtsvorschriften der Union: / Het hierboven beschreven voorwerp is in overeenstemming de desbetreffende harmonisatiewetgeving van de Unie: / Föremålet för försäkran ovan överensstämmer med den relevanta harmoniserade unionslagstiftningen:</p>		
<p align="center">2014/30/EU EMC Directive 2006/42/EC Machinery Directive 2011/65/EU and 2015/863/EU RoHS Directive</p>		
<p>References to the relevant harmonised standards: / Riferimento alle pertinenti norme armonizzate: / Referencias a las normas armonizadas: / Références des normes harmonisées: / Angabe der einschlägigen harmonisierten Normen: / Vermelding van de toegepaste relevante geharmoniseerde normen: / Hänvisningar till de relevanta harmoniserade standarder:</p>		
<p>EN ISO 13849-1:2015</p>	<p>SAFETY OF MACHINERY – SAFETY-RELATED PARTS OF CONTROL SYSTEMS – PART 1: GENERAL PRINCIPLES FOR DESIGN (UP TO CAT.4 PLE)</p>	
<p>EN ISO13849-2:2012</p>	<p>SAFETY OF MACHINERY – SAFETY-RELATED PARTS OF CONTROL SYSTEMS – PART 2: VALIDATION</p>	
<p>EN 62061:2005 + A2:2015</p>	<p>SAFETY OF MACHINERY - FUNCTIONAL SAFETY OF SAFETY-RELATED ELECTRICAL, ELECTRONIC AND PROGRAMMABLE ELECTRONIC CONTROL SYSTEMS (UP TO SIL 3)</p>	
<p>EN 60947-5-1:2017</p>	<p>LOW VOLTAGE SWITCHGEAR AND CONTROLGEAR- PART 5-1: CONTROL CIRCUIT DEVICES AND SWITCHING ELEMENTS – ELECTROMECHANICAL CONTROL CIRCUIT DEVICES</p>	
<p>Conformity has been certified by the following Notified Body TÜV SÜD Product Service GmbH - Ridlerstraße 65 - 80339 München – (identification n° 0123) with TÜV Certificate No. Z10 070800 0055 Rev. 01. EC-Type Examination Certificate No. M6A 070800 0056 Rev. 01</p>		
<p>Lippo di Calderara di Reno, November 26, 2020 Ruggero Cacioppo Product Quality Leader </p>		

