



## S60...M Background suppression

### INSTRUCTION MANUAL

#### CONTROLS

##### OUTPUT LED

The yellow LED ON indicates that the NO output is closed.

##### READY/ERROR (bicoloured) LED

When permanently green indicates a normal operating conditions and the sensor is ready to function correctly (stability condition). The alternative green / red blinking indicates a wrong detection.

Please refer to the "SETTING" paragraph for acquisition or setup procedure indications.

##### SET PUSHBUTTON

A long pressure on the pushbutton activates the self-setting procedure.

The REMOTE input allows the external SET control.

#### INSTALLATION

The sensor can be positioned by means of the three housing's holes using two screws (M4x25 or longer, 1.5Nm maximum tightening torque) with washers.

Various orientable fixing brackets to ease the sensor positioning are available (please refer to the accessories listed in the general catalogue).

The operating distance is measured from the front surface of the sensor optics.

The M12 connector can be oriented at two different positions using the specific fastening spring and rotating the block of 180°.



#### CONNECTIONS

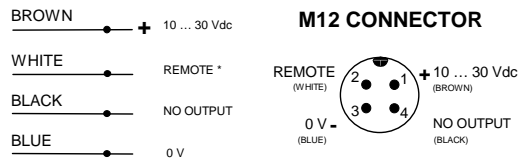

\* = Connect to 0 V the REMOTE wire if not used.

#### TECHNICAL DATA

Power supply:	10 ... 30 VDC (limit values) Class 2 UL508 (reverse polarity protected)
Ripple:	2 Vpp max.
Current consumption (output current excluded):	50 mA max.
Outputs:	PNP or NPN; 30 VDC max. (short-circuit protection)
Output current:	100 mA max.
Output saturation voltage:	≤ 2 V
Response time:	500 μs max.
Switching frequency:	1 KHz
Indicators:	OUTPUT LED (YELLOW) / READY/ERROR LED (GREEN/RED)
Adjustment:	SET pushbutton
Data retention:	EEPROM non volatile memory
Operating temperature:	-10 ... 55 °C
Storage temperature:	-20 ... 70 °C
Electrical shock protection:	Class 2
Operating distance (typical values):	2...20 cm
Spot dimension:	16 mm at 20 cm
Emission type:	RED (670 nm)
Ambient light rejection:	According to EN 60947-5-2
Vibrations:	0.5 mm amplitude, 10 ... 55 Hz frequency, for every axis (EN60068-2-6)
Shock resistance:	11 ms (30 G) 6 shock for every axis (EN60068-2-27)
DARK/LIGHT selection:	LIGHT mode with EASY TOUCH™ / automatic with fine acquisition
Housing material:	ABS
Lens material:	PMMA window; PC lens
Mechanical protection:	IP67
Connections:	M12-4 pole connector
Weight:	40 g. max. connector vers.

#### SETTING

##### EASY TOUCH™

The sensor uses the patent-covered EASY TOUCH™ technology that allows a rapid and safe self-setting of the product.

Two different setting possibilities are available:

- **EASY TOUCH™**; press for 2 sec. of the SET pushbutton allows self-setting.
- **FINE DETECTION**; to be used only in particularly critical conditions, this setting procedure is used only when the EASY TOUCH™ is not sufficient.

##### EASY TOUCH™ (STANDARD DETECTION)

Place the background or the object to be suppressed inside the operating range.

Press the SET pushbutton until the READY/ERROR LED turns OFF.

Release the SET pushbutton and wait for the READY/ERROR LED to turn green.

The sensor is now ready to detect all objects in the operating field distinguishing them from the suppressed background (output LED turns ON).

##### FINE DETECTION

Place the background or the object to be detected inside the operating range.

Press the SET pushbutton and keep it pressed until the READY/ERROR LED blinks green.

Place the object to be suppressed inside the operating distance.

Press again the SET pushbutton until the READY/ERROR LED turn OFF.

The sensor selects the best operating conditions according to the acquired points and adjusts itself in the LIGHT mode condition.

The given acquisition sequence has to be inverted to select the DARK mode.

#### DIMENSIONS

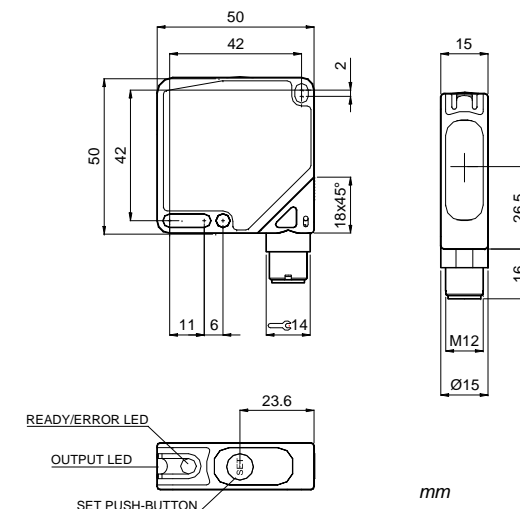

#### DELAY FUNCTION

Press the SET pushbutton and keep it pressed until the READY/ERROR LED turns off, blinks and turns off again, then release the SET pushbutton.

If the delay function *is not active* the READY/ERROR LED blinks green with 2 quick pulses.

If the delay function *is active* the READY/ERROR LED blinks green with 4 quick pulses. Press and release immediately the SET pushbutton in order to change the function status, the new function status is indicated by the READY/ERROR LED as the mode before described. The delay function adds 20ms to the duration of the sensor's ON pulse.

#### REMOTE FUNCTION

The REMOTE wire connected to +VDC is equal to pressing the SET pushbutton. The *keyboard block* is activated if at the sensor powering the REMOTE wire is connected +VDC, and thus the SET pushbutton is no longer active.

To deactivate the *keyboard block* the sensor has to be turned off and then turned on with the REMOTE wire not connected.

*The sensors are NOT safety devices, and so MUST NOT be used in the safety control of the machines where installed.*

##### Datalogic S.r.l.

Via S. Vitalino 13 - 40012 Calderara di Reno - Italy  
Tel: +39 051 3147011 - Fax: +39 051 3147205 - www.datalogic.com

Helpful links at [www.datalogic.com](http://www.datalogic.com): **Contact Us, Terms and Conditions, Support.**

The warranty period for this product is 36 months. See General Terms and Conditions of Sales for further details.

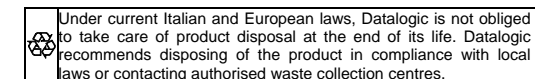

© 2007 - 2017 Datalogic S.p.A. and/or its affiliates • ALL RIGHTS RESERVED. • Without limiting the rights under copyright, no part of this documentation may be reproduced, stored in or introduced into a retrieval system, or transmitted in any form or by any means, or for any purpose, without the express written permission of Datalogic S.p.A. and/or its affiliates. Datalogic and the Datalogic logo are registered trademarks of Datalogic S.p.A. in many countries, including the U.S.A. and the E.U. All other trademarks and brands are property of their respective owners. Datalogic reserves the right to make modifications and improvements without prior notification.